

MODELS LCE/LCS, L2E/L2S, L3E/L3S



BELT DRIVE SIDEWALL PROPELLER FANS

LINE OVERVIEW



S&P's Belt Drive Sidewall Propeller Fan line is designed to exhaust or supply large volumes of air at relatively low static pressures. With 3 levels of construction, the belt drive models are for use in a variety of applications for commercial, industrial and agricultural buildings such as manufacturing and assembly plants, warehouses, parking garages, gymnasiums, equipment rooms, distribution centers, foundries, boiler rooms, greenhouses and OEM applications. The direct drive models provide general ventilation for a wide variety of buildings and enclosed areas within buildings. Examples include factories, assembly plants, warehouses, gymnasiums, garages, jails, machine rooms and many others.

These Sidewall Propeller Fans are rated from 3,000 to 85,000 CFM with static pressures to 1" w.g. Models range from 20 to 72". A wide range of accessories are available to meet any need or specification. See the below Model Comparison to find the right Belt Drive Sidewall Propeller Fan for your application.

MODEL COMPARISON

Construction Level		Model	Size Range	Performance	Model Overview On Page
1	 G90 galvanized steel blades bolted to an epoxy coated hub	LCE LCS	20 to 60"	3,000 to 40,000 CFM up to .625" w.g.	23
2	 G90 galvanized steel blade bolted to a welded, structural steel hub plate	L2E L2S	24 to 60"	5,000 to 47,000 CFM up to .75" w.g.	24
3	 G90 galvanized steel with double 16 gauge laminations bolted to a welded, structural steel hub plate	L3E L3S	42 to 72"	35,000 to 85,000 CFM up to 1" w.g..	25

MOUNTING ARRANGEMENT OPTIONS

Page	Mounting Arrangement	Description
12-13	Wall Housing 	Heavy-gauge, all galvanized G-90 steel housing provides a simple solution to installing a fan and all required accessories in a rough wall opening. It can be used in exhaust or supply applications and in fan sizes 20 through 72 inch.
14-15	Filtered Wall Housing 	For installations where filtering is required. Heavy-gauge, all galvanized G-90 steel filtered wall housings are available in both supply and exhaust configurations. They are available in eight (8) sizes for fans ranging from size 20 to 60 inches. They are designed with the draw-thru concept to achieve the highest filter and fan efficiencies.
16	Wall Collar 	Heavy-gauge, all G-90 galvanized mounting collar provides a simple solution to installing a fan in a rough wall opening when a rear safety guard is NOT required.



WALL HOUSING MOUNTING OPTIONS

This heavy-gauge, all galvanized G-90 steel housing provides a simple solution to installing a fan and all required accessories in a rough wall opening. It can be used in exhaust or supply applications and in fan sizes 20 through 72 inch. Depending on space and maintenance requirements, the wall housing may be installed inward or outward of the building. All housings ship assembled with the fan to lessen job site installation costs. Wire guards, shutters and/or rainhoods may be attached to the prepunched flange. We strongly recommend rainhoods and motorized shutters for all supply applications and whenever additional weather protection is desired.

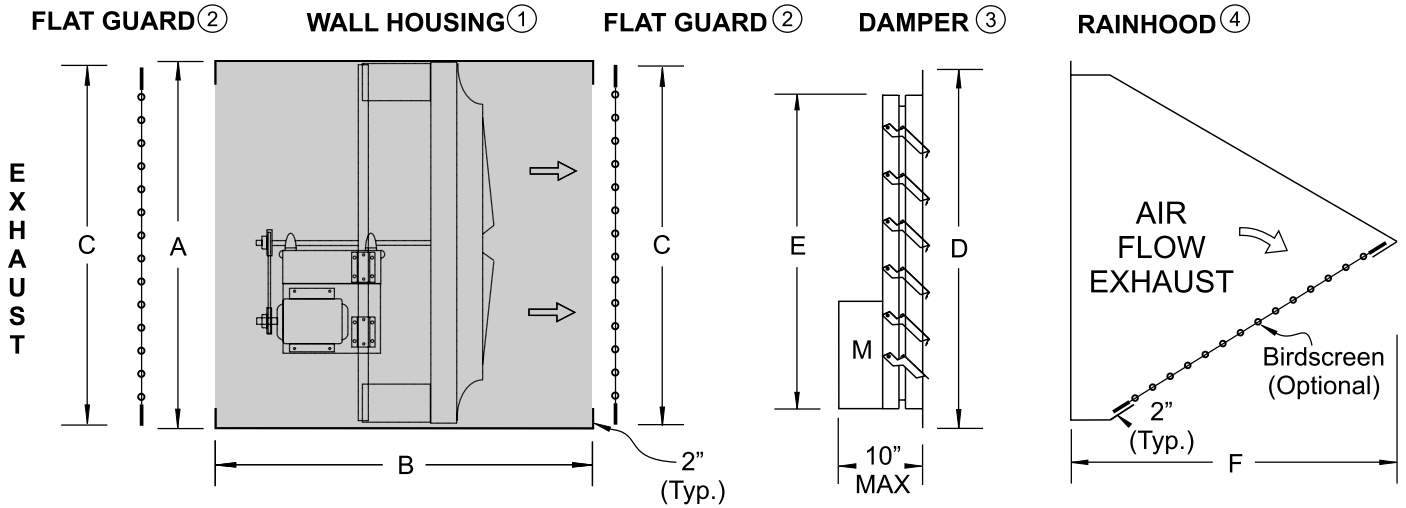
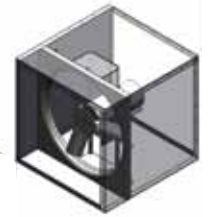

Fan Size	Wall Housing ①		Minimum Wall Opening	Flat Guard ②	Damper ③		Exhaust	Supply
	A (Sq.) O.D	B Length			Optional Rainhood 45 Deg. ④	Required Rainhood 90 Deg. ⑤		
		Exh/Sup						
LC, L2 & L3	(Sq)	C (Sq)	D (O.D)	E	F	F		
20	25	44 or 32	25 1/2	24	22 1/2	20	24 1/4	27 3/4
24	31	44 or 32	31 1/2	30	28 1/2	26	28 1/2	38 1/2
30	37	44 or 32	37 1/2	36	34 1/2	32	34 1/2	44 1/2
36	43	44 or 32	43 1/2	42	40 1/2	38	40 1/2	49
42	49	44 or 32	49 1/2	48	46 1/2	44	44 1/2	56 1/2
48	55	44 or 32	55 1/2	54	52 1/2	50	49 1/2	62 1/2
54	61	44	61 1/2	60	58 1/2	56	55	73
60	67	44	67 1/2	66	64 1/2	62	69	73
72	81	44	81 1/2	80	78 1/2	76	75 1/2	73

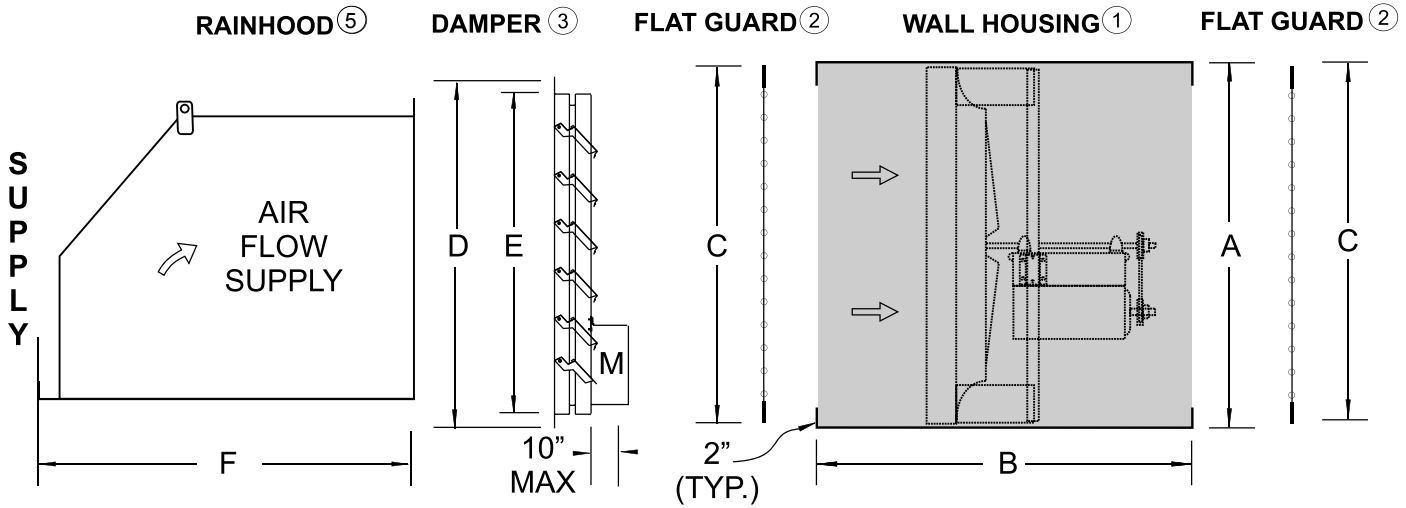

Rainhood recommended for supply applications.



WALL HOUSING STANDARD MOUNTING ARRANGEMENTS

The most common mounting arrangement (below left) leaves a clean building exterior and allows access to the fan, motor and drives from inside the building. Additional bracing angle, rod or cable (field provided) should be used in addition to the mounting angles to support the fan and wall housing assembly.

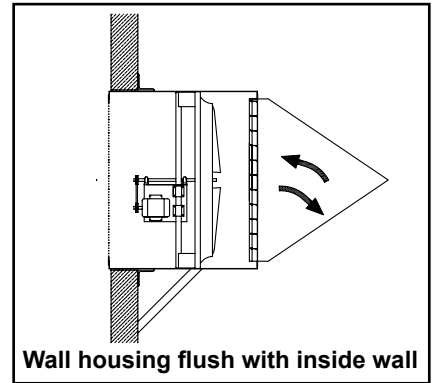
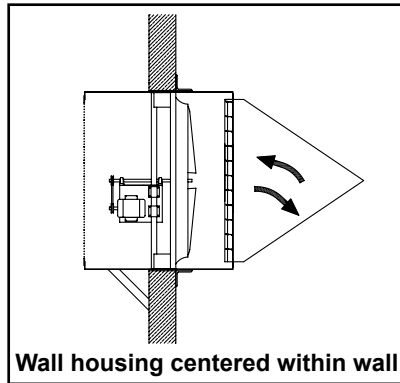
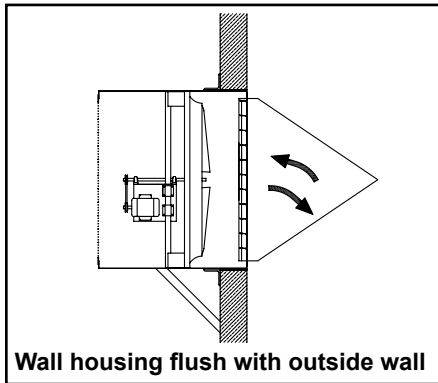

NOTE: Supply applications have the fan venturi spun on the opposite side of the fans shown above. The fans shown are exhaust. Rainhoods are required on supply applications and recommended on exhaust applications where additional weather protection is desired. Exhaust and/or supply fans installed as shown should be serviced from the interior of the building. Where service is required from the exterior of the building, consult the factory or representative for recommendations. All bracing shown is field provided. Field flashing and caulking of wall housing seams and unused mounting holes, will ensure a weather resistant installation.

PRESSURE LOSS GUIDE FOR WALL HOUSING ACCESSORIES

Use the estimated pressure drop graphs to help select the proper exhaust or supply fan package that will deliver the desired airflow. Enter the graph from the bottom at the specified CFM and move vertically upward to the fan curve for the desired fan size, then horizontally to the left and read the estimated static pressure drop resulting from these typical accessory packages. Add the accessory pressure loss to the system (or building) design static pressure loss to obtain the total static pressure loss to be used for the proper fan selection.

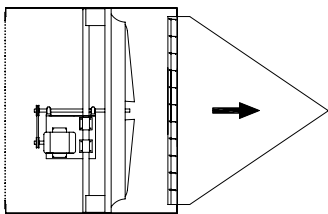

Exhaust Airflow
 with Wall Housing
 Gravity Damper
 Rainhood
 Motorside Guard

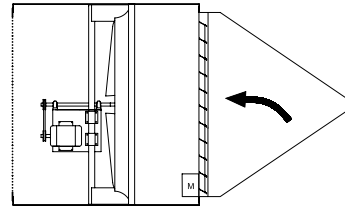

Supply Airflow
 with Wall Housing
 Gravity Damper
 Rainhood
 Motorside Guard

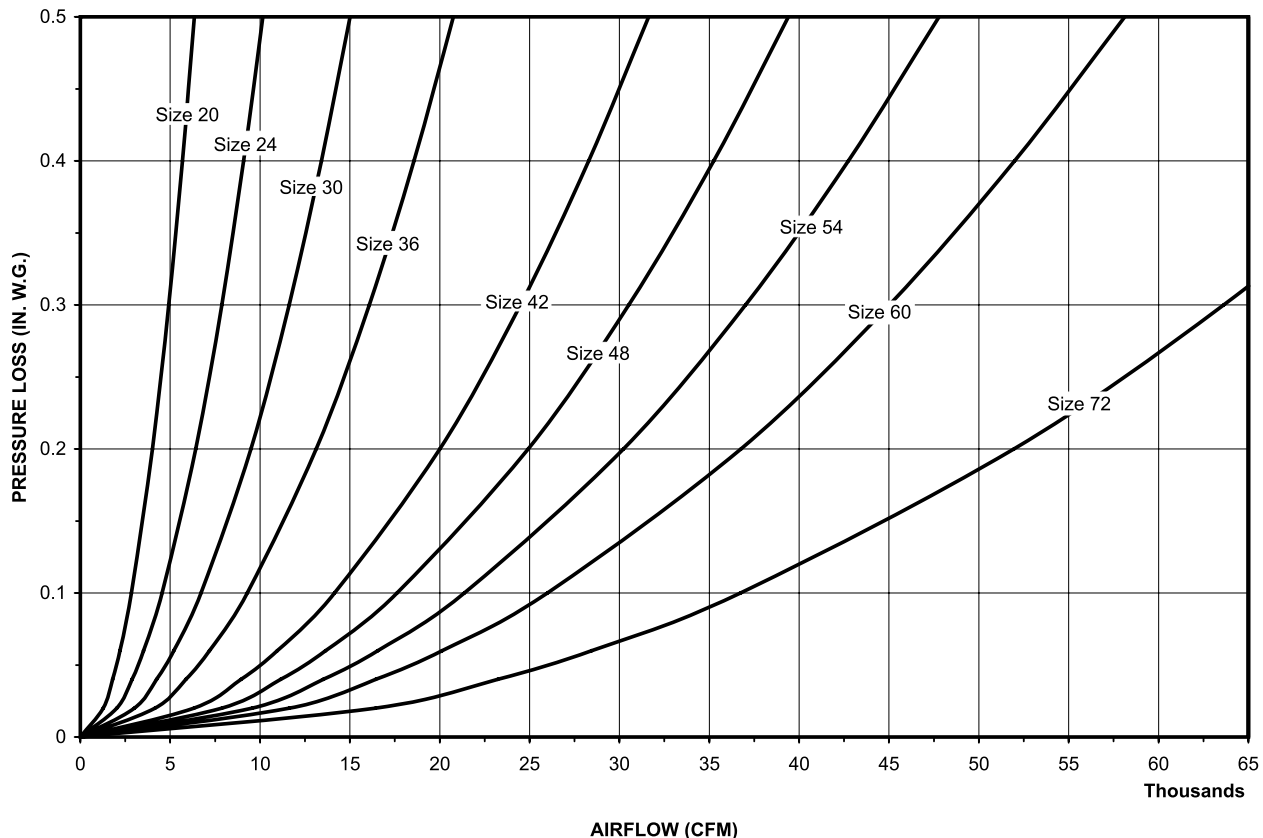

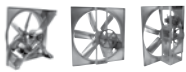

FILTERED WALL HOUSING MOUNTING OPTIONS

Filtered wall housings are available in both supply and exhaust configurations. They are available in eight (8) sizes for fans ranging from size 20 to 60 inches. They are designed with the draw-thru concept to achieve the highest filter and fan efficiencies.

Standard construction is galvanized steel. Mounting flanges are factory installed for either flush exterior or flush interior. Permanent 2-inch (51 mm) washable filters are accessed through a bolted or hinged panel and can be easily removed for cleaning.

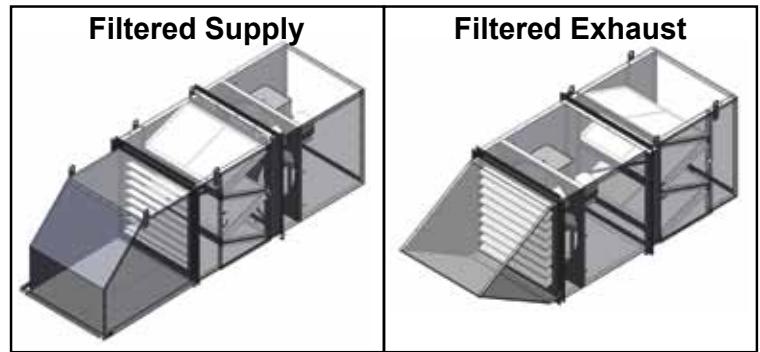

FILTERED SUPPLY WALL HOUSING

Standard Features and Options

1. **Wall Housing Box (Standard)**
2. **Filter Box (Standard)**
 - Bolted or Hinged Door
 - Includes 2 sets of flanges for mounting filter box to wall housing.
3. **Wall Mount Flanges (Standard)**
 - Set of 4 - shipped loose
4. **Damper ()**
 - Supply Type
 - Gravity, Motorized, or Center Pivot
5. **Rain Hood (Optional)**
 - 90 Degree - Supply Type

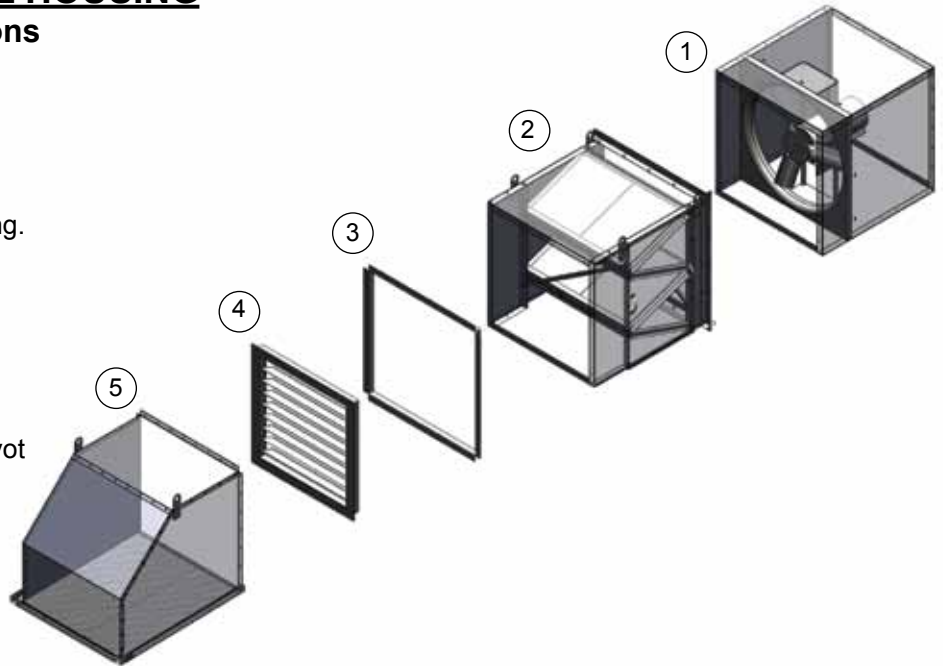

FILTERED EXHAUST WALL HOUSING

Standard Features and Options

1. **Wall Housing Box (Standard)**
2. **Filter Box (Standard)**
 - Bolted or Hinged Door
 - Includes 2 sets of flanges for mounting filter box to wall housing.
3. **Wall Mount Flanges (Standard)**
 - 1 set of 4 - shipped loose
4. **Damper (Optional)**
 - Exhaust Type
 - Gravity, Motorized, or Center Pivot
5. **Rain Hood (Optional)**
 - 45 Degree - Exhaust Type

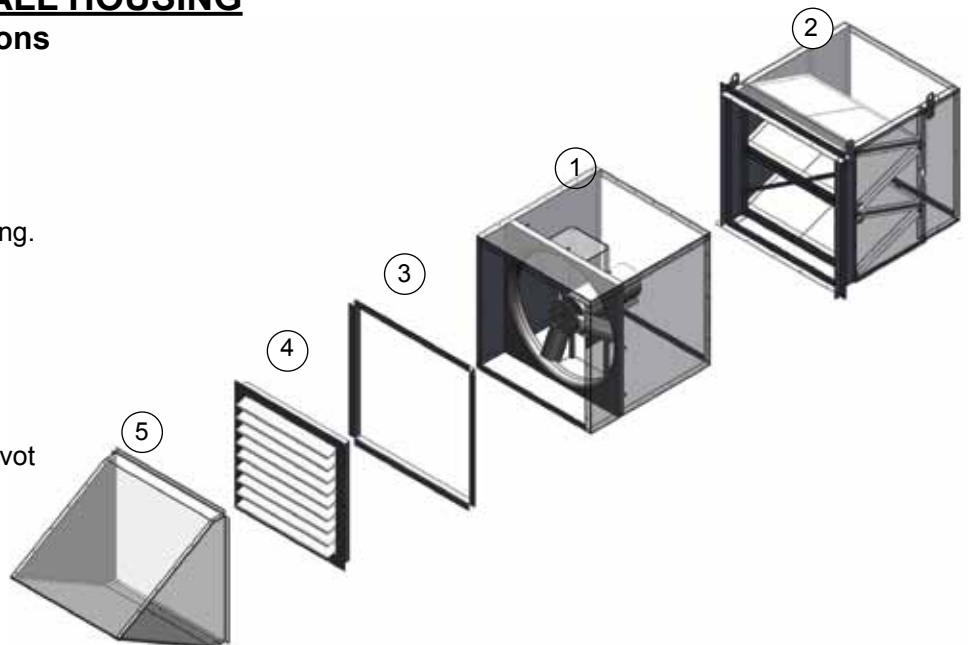



FILTERED WALL HOUSING MOUNTING OPTIONS Cont.

Filtered Wall Housing Dimensions

Filtered Supply

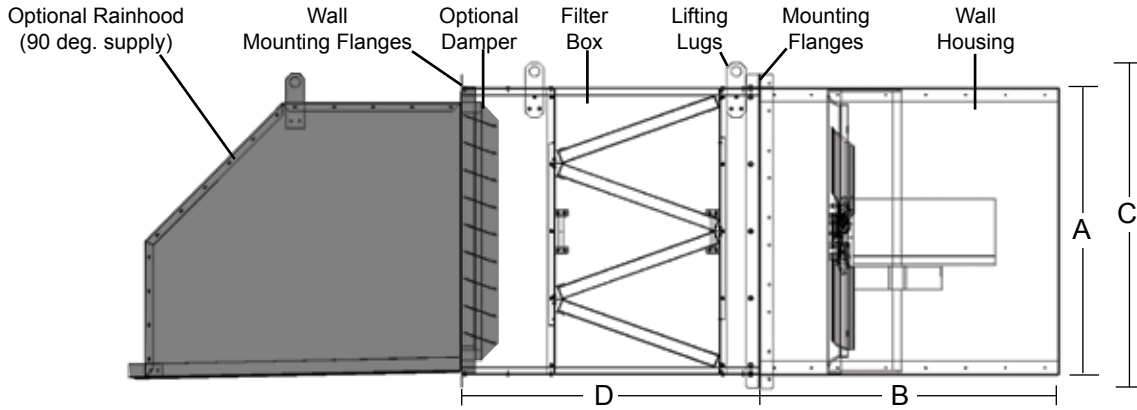

Fan Size	Wall Housing		Minimum Wall Opening Sq	Filter Box			
	A	B Length LC & L2		C	D	# of Filters	Filter Actual Dimensions
20	25	44-32	25 1/2	25	44 1/8	3	19 5/8 x 24 5/8 x 1 7/8
24	31	44-32	31 1/2	31	41 1/8	4	19 5/8 x 24 5/8 x 1 7/8
30	37	44-32	37 1/2	37	44 1/8	8	15 5/8 x 24 5/8 x 1 7/8
36	43	44-32	43 1/2	43	44 1/8	8	19 5/8 x 24 5/8 x 1 7/8
42	49	44-32	49 1/2	49	44 1/8	10	19 5/8 x 24 5/8 x 1 7/8
48	55	44-32	55 1/2	55	40 1/2	12	19 5/8 x 24 5/8 x 1 7/8
54	61	44	61 1/2	61	44 1/8	15	19 5/8 x 24 5/8 x 1 7/8
60	67	44	67 1/2	67	44 1/8	15	19 5/8 x 24 5/8 x 1 7/8

Filtered Exhaust

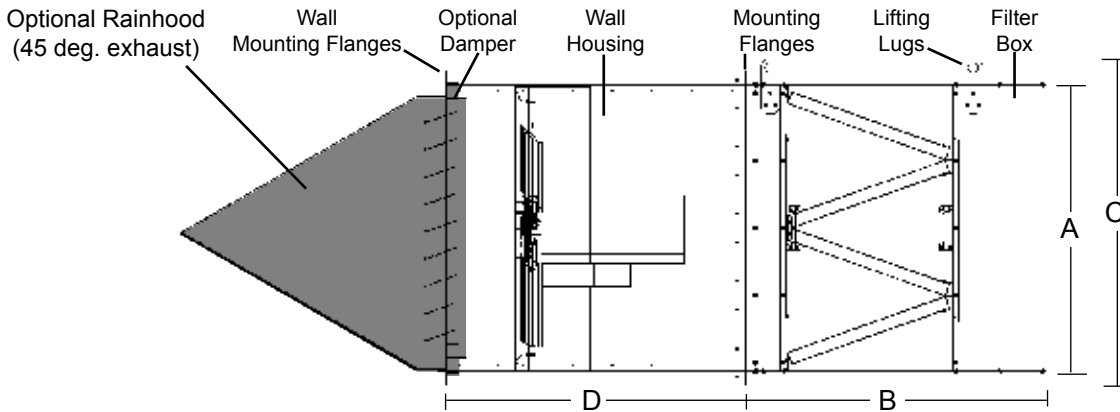

PRESSURE LOSS GUIDE FOR FILTER BOX

Use the estimated pressure drop graphs to help select the proper exhaust or supply fan that will deliver the desired airflow. Enter the graph from the bottom at the specified CFM and move vertically upward to the fan curve for the desired size, then horizontally to the left and read the estimated static pressure drop resulting from these typical accessory packages. Add the accessory pressure loss to the system (or building) design static pressure loss to obtain the total static pressure loss to be used for the proper fan selection.

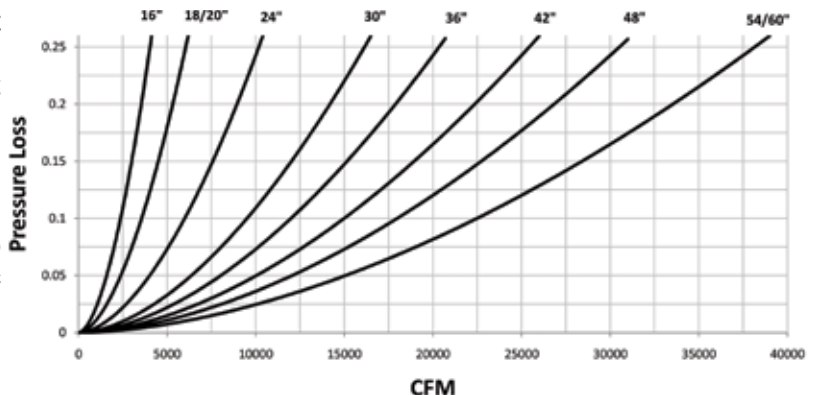



WALL COLLAR MOUNTING OPTION

The heavy-gauge, all G-90 galvanized mounting collar provides a simple solution to installing a fan in a rough wall opening when a rear safety guard is **NOT** required. A front wire guard, shutter, and/or rainhood can be attached to the front prepunched flanges. The wall collar can be used in exhaust or supply applications for all fan sizes. The wall collar is mounted with the fan on the interior side of the building. All collars ship fully assembled with the fan to lessen jobsite installation costs. We strongly recommend rainhoods and motorized shutter for all supply applications as well as for exhaust applications where additional weather protection is desired.

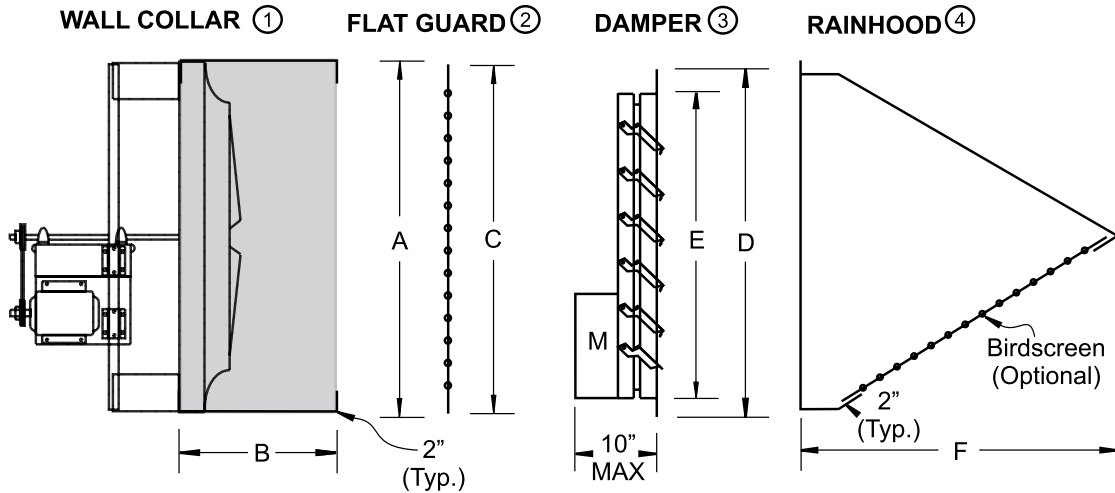
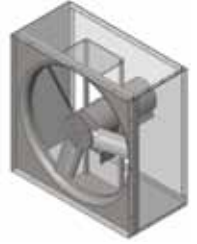



Dimensions

Fan Size	Wall Collar ①		Minimum Wall Opening	Flat Guard ②	Damper ③		Rainhood ④
	A	B	Sq	C	D (O.D)	E	F
20	24 1/4	21	25 1/2	24	22 1/2	20	24 1/4
24	30 1/4	21	31 1/2	30	28 1/2	26	28 1/2
30	36 1/4	21	37 1/2	36	34 1/2	32	34 1/2
36	42 1/4	21	43 1/2	42	40 1/2	38	40 1/2
42	48 1/8	21	49 1/2	48	46 1/2	44	44 1/2
48	54 1/8	21	55 1/2	54	52 1/2	50	49 1/2
54	60 1/8	21	61 1/2	60	58 1/2	56	55
60	66 1/8	21	67 1/2	66	64 1/2	62	69
72	80 1/8	26	81 1/2	80	78 1/2	76	75 1/2

(a) Level 3 Construction requires a deeper motorside guard as shown.
 Unless shown otherwise supply and exhaust dimensions are similar.

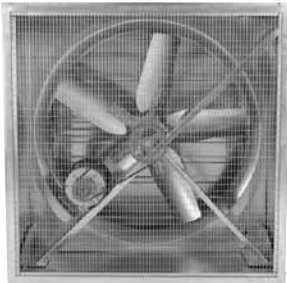

ACCESSORIES & OPTIONS FOR MOUNTING ARRANGEMENTS

Accessory or Option	
	<p>Safety Guards Safety Guards (Standard or Heavy-Duty Flat Guards) are strongly recommended to protect personnel from accidental injury and to prevent debris from entering the fan. OSHA approved guards are required in many installations including when the fans are within 7 feet of the floor or work/access area.</p>
	<p>Rainhoods or Weatherhoods Designed to provide additional weather protection by partially shielding the wall opening and should be used for all supply applications and whenever additional weather resistance is desired. The galvanized (aluminum optional) hood attaches to the wall housing or wall collar flanges. Field flashing and caulking will reduce moisture penetration. Shown with optional birdscreen.</p>
	<p>Dampers Used alone or in conjunction with the wall housing or wall collar, a complete line of dampers are available for exhaust or supply configurations.</p>



ACCESSORIES & OPTIONS FOR MOUNTING ARRANGEMENTS Cont.

Safety Guards

Safety guards are strongly recommended to protect personnel from accidental injury and to prevent debris from entering the fan. OSHA approved guards are required in many installations including when the fans are within 7 feet of the floor or work/access area.

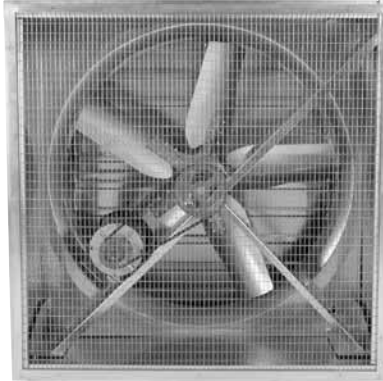
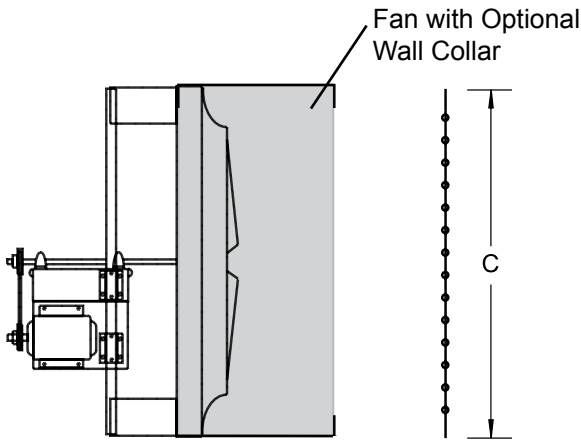

Standard Duty Flat Wire Guard

The removable safety guard satisfies OSHA requirements when used with the optional wall housing as a motor-side (rear) guard. The 16 ga. 1/2" X 1" welded wire mesh is mounted in a galvanized frame and attaches to the inward flanges of the wall housing.

Dimensions

Fan Size	C
20	24
24	30
30	36
36	42
42	48
48	54
54	60
60	66
72	80

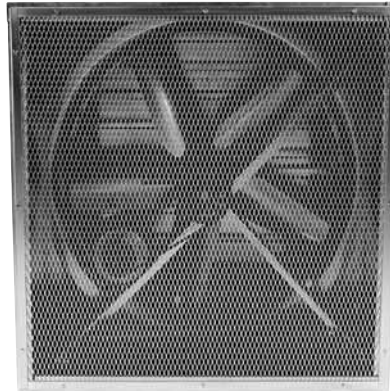

Heavy-Duty Flat Wire Guard

The removable safety guard satisfies OSHA requirements when used with the optional wall housing as a motor-side (rear) guard. The H.D. expanded aluminum mesh is mounted in a galvanized frame and attaches to the inward flanges of the wall housing.



ACCESSORIES & OPTIONS

FOR MOUNTING ARRANGEMENTS Cont.

Rainhoods or Weatherhoods

Designed to provide additional weather protection by partially shielding the wall opening and should be used for all supply applications and whenever additional weather resistance is desired. The galvanized (aluminum optional) hood attaches to the wall housing or wall collar flanges. Field flashing and caulking will reduce moisture penetration. Shown with optional birdscreen.



45 Degree Exhaust

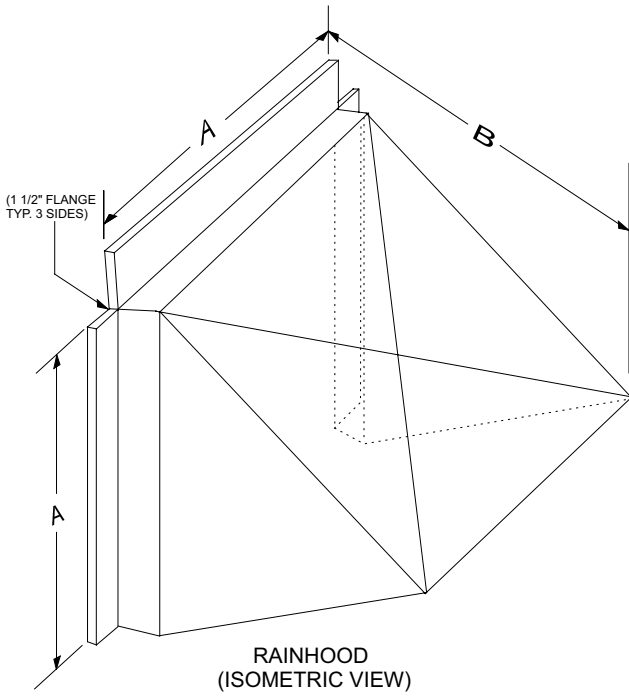

RAINHOOD
(ISOMETRIC VIEW)

Fan Size	A	B	GAUGE (2)	AVG. WT.
20	22	24-1/4	18	25
24	28	28-1/2	18	30
30	34	34-1/2	18	40
36	40	40-1/2	18	50
42	46	46-1/2	18	60
48	52	49-1/2	16	70
54	58	58-1/2	16	120
60	64	64-1/2	16	175
72	78	64-1/2	16	200

90 Degree Supply

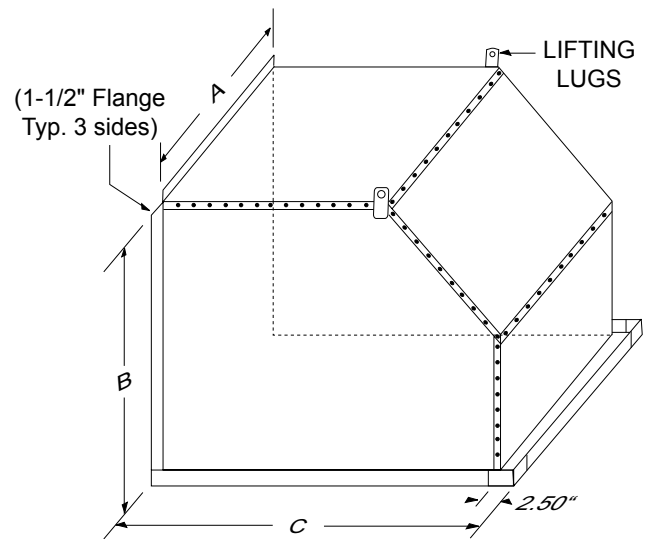

Fan Size	A	B	C	GAUGE (2)	AVG. WT.
20	22	22	27-3/4	18	25
24	27-1/4	26-1/2	38-1/2	18	30
30	32-1/2	33-1/2	44-1/2	18	40
36	38-1/2	39-1/4	49	18	50
42	44-1/2	45-1/4	56-1/2	18	60
48	50-1/2	51-1/2	62-1/2	18	70
54	56-3/4	57	73	18	120
60	62-3/4	63	73	18	175
72	76-3/4	76-3/4	73	18	200



ACCESSORIES & OPTIONS **FOR MOUNTING ARRANGEMENTS Cont.**

Damper Types (Shutters)

Heavy-Duty Galvanized Exhaust Motorized Shutter



This damper has a flanged frame and is designed to fit the inside flanges of the optional wall housing or wall mounting collar. The frame and blades are constructed of galvanized steel and are rated to 3000 FPM with proper clearance as provided by all factory accessories. The damper body recesses into the opening for a flush appearance.

Standard Duty Aluminum Exhaust Gravity Shutter



This damper can greatly reduce the infiltration of outside air and although not completely watertight, will provide weather protection in an economical fashion. Constructed with a galvanized frame and aluminum blades this damper is rated to 2000 FPM with the proper clearance as provided by all factory accessories. The damper body is recessed into the opening for a flush appearance.

Heavy-Duty Galvanized Supply Motorized Shutter



The motorized option improves weather protection by providing a tighter closure seal and is recommended for all supply applications. Heavy-duty dampers are constructed with galvanized frames and blades and are rated to 3000 FPM. The damper body is not recessed providing extra clearance between the fan and damper blades.

Standard Duty Aluminum Supply Motorized Shutter



The motorized option improves weather protection by providing a tighter closure seal and is recommended for all supply applications. Standard duty dampers are constructed with galvanized frames and aluminum blades and are rated to 2000 FPM. The damper body is not recessed providing extra clearance between the fan and damper blades.

Center Pivot Motorized Damper - Supply or Exhaust



The flanged frame damper is designed to recess inside the flanges of the optional wall housing or wall mounting collar. The center pivot style damper provides superior weather resistance. Galvanized (optional aluminum) construction is rated to 3500 FPM with proper clearance as provided by all factory accessories.

Electric Damper Operators

Electric damper operators provide more positive open and closed damper positions which helps increase weather resistance. Power open - spring close (POSC) motor and linkage kits are field installed (except for center pivot style) and are available in 24, 120/240, or 460 volts (single phase) and require approximately 0.5 amps at 120/1/60 power supply. Transformers are available for voltage reduction. For fan motors 5HP and larger, we recommend a factory tilt switch or "delay-on" timer in the control circuit (by others) to allow the damper to open prior to allowing fan operation, which will protect the damper blades and fan from damage when the fan is first energized.



ACCESSORIES & OPTIONS

FOR MOUNTING ARRANGEMENTS Cont.

Dimensions (Standard and Heavy-Duty Dampers)

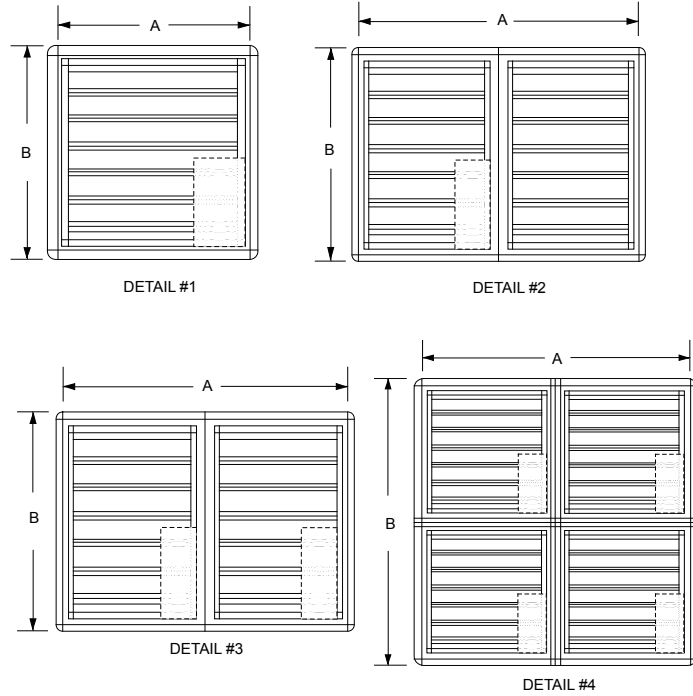
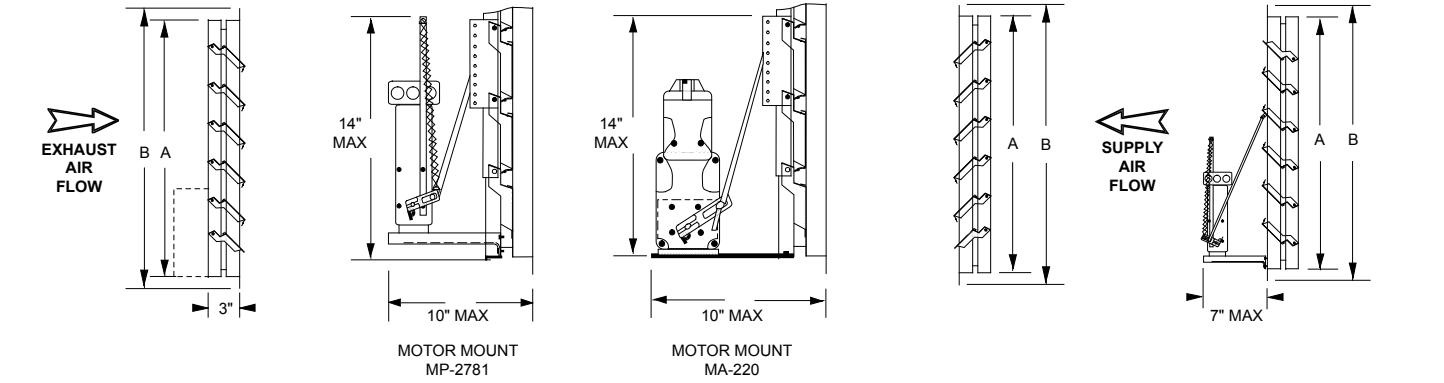

Fan Size	A Sq. Size	B Sq. OD Flange	Panels (Detail)	Motor Type			
				Exhaust		Supply	
				Type	Qty	Type	Qty
20	20	22 1/2	1	MP-2781	1	MP-2781-S	1
24	26	28 1/2	1	MP-2781	1	MP-2781-S	1
30	32	34 1/2	1	MP-2781	1	MA-220-S	1
36	38	40 1/2	1	MA-220	1	MA-220-S	1
42	44	46 1/2	2	MA-220	1	MA-220-S	2
48	50	52 1/2	2	MA-220	1	MA-220-S	2
54	56	58 1/2	3	MA-220	2	MA-220-S	2
60	62	64 1/2	3	MA-220	2	MA-220-S	2
72	77	79 1/2	4	MA-220	4	MA-220-S	4

Heavy Duty Dampers required on all units with 7 1/2HP motors and above.

Dimensions (Center Pivot Motorized Damper)

Fan Size	Opening Required	A O.D.	B (1)	C "Size"	D (Center of Holes)	# of Panels	G	
							Closed (E-1)	Open (E-2)
24	27	29	24-1/2	26	-	1 x 1	7-1/4	8-1/2
30	33	35	30-1/2	32	-	1 x 1	10-1/4	13-3/4
36	39	41	36-1/2	38	19-1/2	1 x 1	10-1/4	13-3/4
42	45	47	42-1/2	44	22-1/2	1 x 1	10-1/4	13-3/4
48	51	53	48-1/2	50	25-1/2	2 x 1	10-1/4	13-3/4
54	57	59	54-1/2	56	28-1/2	2 x 1	10-1/4	12-3/4
60	63	65	60-1/2	62	31-1/2	2 x 1	10-1/4	12-3/4
72	77	79	76-1/2	76	39-1/2	2 x 1	10-1/4	12-3/4

Fan Size	Motor (2)		
	Power Supply	Max Amps	Stall Torque (in. lbs)
24-48	120-240V 60Hz	0.3/0.6	25
54-60	240V 60Hz	0.5	60

(1) Minimum opening to clear pins.
(2) Motor is 60 Hz, single phase continuous duty with 104°F (40°C), maximum ambient temperature

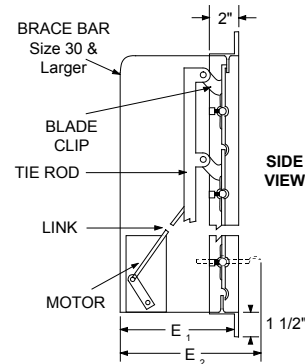
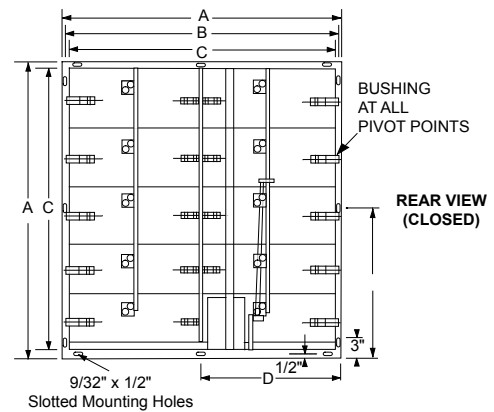



ACCESSORIES & OPTIONS

Electrical Accessories are available to simplify the installation and reduce the total project cost.

Disconnect Switches can be shipped loose or factory mounted and wired (except explosion proof and two speed) in NEMA 1, 3R, 4X, or other enclosures. Two-speed and explosion proof disconnects are available but may be subject to more stringent code requirements. It is the responsibility of the buyer and the installer to comply with all local and national codes.

Aluminum Construction is available for most models and typically includes propeller blades, fan panel, motor and drive support (large frame motors may have steel reinforcement) and accessories. When an explosion proof motor is specified, aluminum fan construction must be used for additional spark resistance.

cULus705 or UL705 Listing is available for sidewall propeller fans with most motors and should be specified for electrical safety and reliability.

Extended Lube Lines provide convenient access for routine bearing lubrication. Lubrication lines are installed from the fan shaft bearings to the exterior of the wall housing or sheet metal motorside guard and are provided with zerk fittings.

Paints and Coatings for protective and decorative purposes. Available coatings include: Epoxy, Synthetic Resin, and Heresite (air-dried phenolic). Contact your Soler & Palau representative or the factory for more information on available coatings and colors.

Mounting Angles facilitate the installation and a secure attachment of the wall housing or wall collar into the framed wall opening. Galvanized or aluminum angles are available and are pre-cut to the proper length. Additional bracing, mounting hardware, flashing and caulking are typically provided by the installer.

Factory Wiring can simplify jobsite installation and reduce the overall project cost. Optional services include wiring of motor, disconnect switch, damper actuator, and other custom controls. Please note that some wiring options may not be available in conjunction with the cULus705 and UL705 listing option (for example explosion proof, two speed and special motors).



MODEL LC - CONSTRUCTION LEVEL 1

Application

Model LCE (exhaust) and LCS (supply) are high capacity belt driven propeller fans rated from 3,000 to 40,000 cfm to .625" w.g. static pressure. Their primary application is the exhaust or supply of large volumes of air at relatively low static pressures from commercial, light industrial and agricultural buildings such as manufacturing and assembly plants, warehouses, parking garages, gymnasiums, equipment rooms, distribution centers, poultry and greenhouses.

Wall mounting provides an easy, economical installation. Belt driven fans provide large volumes of air at low fan speeds and low noise levels and afford quick, easy performance adjustments. All necessary accessories are available to meet any need or specification.

When suspended from the ceiling, thus keeping floor spaces open, model LC can be installed to direct large volumes of air downward toward work centers improving employee comfort and productivity.

When mounted in portable housings with OSHA guards, Model LC-P can be used as a mancooler and rolled to hot spots to provide needed employee relief from heat or fumes and help increase productivity.

Construction/Specification Checklist

Belt Drive, Wall Exhaust (or Supply) Propeller Fan shall be provided as follows:

CERTIFICATIONS: Fans shall be AMCA Licensed for air and sound performance. Fans shall be UL and CUL 705 listed for electrical safety and reliability (Optional).

PANEL ASSEMBLY: Panels shall be heavy-gauge G90 galvanized (optional aluminum) with spun one piece venturi. Motor and bearing plate shall be a minimum of 12 gauge galvanized steel except size 20. Panel end support frame assembly shall be of welded, not bolted, construction with prepunched mounting holes for easy installation.

PROPELLER: Blades shall be die formed galvanized G90 steel of minimum 16 gauge. Blades shall be bolted to an epoxy coated hub which is keyed to the fan shaft. Propeller assembly shall be statically balanced.

DRIVES: All sheaves shall be sized to a minimum 150% of driven horsepower, machined cast iron adjustable pitch through 3 horsepower, keyed to both the motor and fan shaft. Fan shaft shall be precision turned, ground and polished steel. Belts shall be nonstatic oil and heat resistant V-belts.

BEARINGS: All bearings shall be self-aligning cast iron pillow block type with relube fitting and of the air handling design. Bearing design shall be for a minimum of L-50 200,000 hour average life.

MOTORS: Permanently sealed ball bearing type furnished to the specified voltage, phase and enclosure. All motors shall be mounted and factory run tested.



Fan Size	Material (Ga. or inches)					Shaft Diameter (in.)	Max Motor Frame Size	Avg. Weight (lbs.)
	Fan Panel	Drive Frame	Motor & Bearing Supports	Propeller				
				Spider Steel	Blade Steel			
20	18	16	16	14	18	3/4	56H	85
24	16	12	12	10	16	1	145T	90
30	16	12	12	10	16	1	145T	100
36	16	12	12	7	16	1	145T	105
42	16	12	12	7	14	1	145T	110
48	16	12	12	7	14	1	145T	125
54	14	12	12	1/4	12	1 3/16	182T	240
60	14	12	12	1/4	12	1 3/16	182T	285

Motor Service Factor

Motor service factors are utilized in some performance selections shown. This is a safe and common industry practice that provides more performance for the investment. BHP is shown at the maximum catalog performance point. BHP at all other static pressures listed is less than that shown, in most cases substantially less. Because the motors are in the air stream there are no negative effects on motor life. 2 speed motor applications are recommended at or below their nominal BHP levels. If desired, pick the next higher horsepower to eliminate this service factor usage. Refer to the Optimizer Fan Selection Program for actual BHP at any performance point.

DIMENSIONS

Fan Size	A Sq	B	C	D	E	F	Damper O.D. Sq Flange
20	24	2	5	1 1/4	15	23	22 1/2
24	30	2	7 1/2	1 1/4	15	23	28 1/2
30	36	2	7 1/2	1 1/4	15	24	34 1/2
36	42	2	7 1/2	1 1/4	15	24	40 1/2
42	48	2	7 1/2	1 1/4	16	24	46 1/2
48	54	2	7 1/2	1 1/4	16	24	52 1/2
54	60	2	7 1/2	1 1/4	20	26	58 1/2
60	66	2	7 1/2	1 1/4	20	26	64 1/2

Dimensions shown in inches.

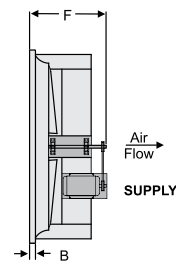
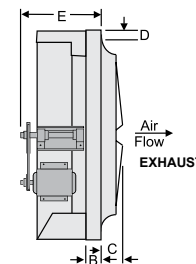
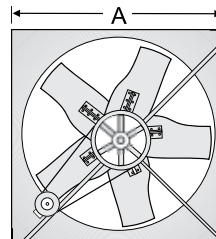

1 year fan housing warranty, 1 year motor warranty



MODEL L2 - CONSTRUCTION LEVEL 2

Application

Models L2E (exhaust) and L2S (supply) are high capacity wall mounted belt driven propeller fans rated from 5000 to 47,000 CFM and to .75" w.g. static pressure. Their primary application is the exhaust of large volumes of ventilation air from commercial and light industrial buildings such as manufacturing and assembly plants, warehouses, parking garages, gymnasiums, equipment rooms, distribution centers and OEM applications.

Wall mounting provides an easy and economical installation. All necessary accessories are available. Belt driven fans provide large volumes of air at low fan speed and low noise levels and afford quick, easy performance adjustments.

See Model L - Construction level 3 for higher static pressures and heavier construction designs or models LC for your lighter duty ventilation requirements.

Construction/Specification Checklist

Belt Drive, Wall Exhaust (or Supply) Propeller Fan shall be provided as follows:

CERTIFICATIONS: Fans shall be AMCA Licensed for air and sound performance. Fans shall be UL and cUL 705 listed for electrical safety and reliability (Optional).

PANEL ASSEMBLY: Panels shall be heavy-gauge G90 galvanized (optional aluminum) with spun one piece venturi. Motor and bearing plate shall be a minimum of 10 gauge G90 galvanized steel. Panel end support frame assembly shall be of welded, not bolted, construction with pre-punched mounting holes for easy installation.

PROPELLER: Propellers shall be six-bladed, die-formed, minimum 16 gauge, G90 galvanized steel bolted to a welded, structural steel hub plate and keyed to the fan shaft. Blades shall incorporate multiple laminations for 3 horsepower motors and larger. Propeller assembly shall be statically balanced.

DRIVES: All sheaves shall be sized to a minimum 150% of driven horsepower, machined cast iron adjustable pitch (through 3HP), keyed to both the motor and fan shaft. Fan shaft shall be precision turned, ground and polished steel. Belts shall be nonstatic oil and heat resistant V-belts.

BEARINGS: All bearings shall be self-aligning cast iron pillow block type with relube fitting and of the air handling design. Bearing design shall be for a minimum of L-50 200,000 hour average life.

MOTORS: Permanently sealed ball bearing type furnished to the specified voltage, phase and enclosure. All motors shall be mounted and factory run tested.

Fan Size	Material (Ga. or inches th.)							Max Shaft Diameter (in.)	Max Motor Frame Size	Avg. Weight (lbs.)
	Fan Panel	Drive Frame	Motor & Bearing Supports		Propeller					
			Galv	Alum	Spider	Blade				
					Steel	Steel	Alum			
24	18	10	10	1/4	1/4	16	.080	1	182T	180
30	16	10	10	1/4	1/4	16	.080	1	182T	180
36	16	10	10	1/4	1/4	16	.080	1 3/16	184T	215
42	16	10	10	1/4	3/8	16	.080	1 3/16	184T	235
48	16	10	10	1/4	3/8	16	.080	1 3/16	184T	300
54	14	10	10	1/4	3/8	16	.080	1 3/16	184T	400
60	14	10	10	1/4	3/8	16	.080	1 3/16	184T	490



DIMENSIONS

Fan Size	A Sq	B	C	D	E	F	Damper O.D. Sq Flange
24	30	2	7 1/2	1 1/4	22	26	28 1/2
30	36	2	7 1/2	1 1/4	22	26	34 1/2
36	42	2	7 1/2	1 1/4	22	26	40 1/2
42	48	2	7 1/2	1 1/4	22	26	46 1/2
48	54	2	7 1/2	1 1/4	22	26	52 1/2
54	60	2	7 1/2	1 1/4	22	26	58 1/2
60	66	2	7 1/2	1 1/4	24	28	64 1/2

Dimensions shown in inches.

Motor Service Factor

Motor service factors are utilized in some performance selections shown. This is a safe and common industry practice that provides more performance for the investment. BHP is shown at the maximum catalog performance point. BHP at all other static pressures listed is less than that shown, in most cases substantially less. Because the motors are in the air stream there are no negative effects on motor life. Explosion proof and 2 speed motor applications are recommended at or below their nominal BHP levels. If desired, pick the next higher horsepower to eliminate this service factor usage. Refer to the Optimizer Fan Selection Program for actual BHP at any performance point.

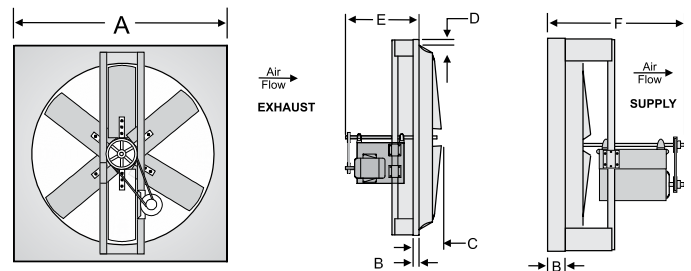

1 year fan housing warranty, 1 year motor warranty



MODEL L3 - CONSTRUCTION LEVEL 3

Application

Models L3E (exhaust) and L3S (supply) are high capacity wall mounted belt driven propeller fans rated from 35,000 to 85,000 and to 1.0" w.g. static pressure. Their primary application is the exhaust of large volumes of air at relatively moderate static pressure from commercial, industrial and agricultural buildings such as manufacturing and assembly plants, warehouses, foundries, mills, boiler rooms and equipment rooms.

Wall mounting provides an easy and economical installation. Belt driven fans provide large volumes of air at low fan speed and low noise levels and afford quick, easy performance adjustments. All required accessories are available with Model L.

See Models LC and L - level 2 construction, for lower static pressures and lighter duty requirements which are generally more economical.

Construction/Specification Checklist

Belt Drive, Wall Exhaust (or Supply) Propeller Fan shall be provided as follows:

CERTIFICATIONS: Fans shall be AMCA Licensed for air and sound performance. Fans shall be UL and CUL 705 listed for electrical safety and reliability (optional).

PANEL ASSEMBLY: Panels shall be heavy-gauge G-90 galvanized (optional aluminum) with spun one piece venturi. Motor and bearing plate shall be a minimum of 10 gauge G90 galvanized steel structurally secured to minimum 1.25 inch schedule 40 galvanized steel pipe by means of 12 gauge galvanized steel pipe brackets. Panel end support frame assembly shall be of welded, not bolted, construction with pre-punched mounting holes for easy installation.

PROPELLER: Propellers shall be six-bladed, die-formed, minimum 16 gauge, G90 galvanized steel with double 16 gauge laminations bolted to a welded, structural steel hub plate and keyed to the fan shaft. Fan shaft shall be precision turned, ground and polished steel. Props shall be statically balanced.

DRIVES: All sheaves shall be sized to a minimum 150% of drive horsepower, machined cast iron adjustable pitch through 3 horsepower, keyed to both the motor and fan shaft. Fan shaft shall be precision turned, ground and polished steel. Belts shall be non-static oil and heat resistant V-belts.

BEARINGS: All bearing shall be self-aligning cast iron pillow block type with relube fitting and of the air handling style. Bearing design shall be for a minimum of L-50 200,000 hour average life.

MOTORS: Permanently sealed ball bearing type furnished to the specified voltage, phase and enclosure. All motors shall be mounted and factory run tested.

Fan Size	Material (Ga. or inches th.)						Max Shaft Diameter (in.)	Max Motor Frame Size	Avg. Weight (lbs.)
	Fan Panel	Drive Frame	Motor & Bearing Supports	Propeller					
				Spider	Blade				
				Steel	Alum				
42	16	10	10	3/8	16	0.080	1 7/16	213T	260
48	16	10	10	3/8	16	0.080	1 7/16	215T	330
54	14	10	10	3/8	16	0.080	2 3/16	256T	500
60	14	10	10	3/8	16	0.080	2 3/16	256T	530
72	12	10	10	3/8	16	0.080	2 3/16	256T	600



DIMENSIONS

Fan Size	A Sq	B	C	D	E	F	Damper O.D. Sq Flange
42	48	2	7 1/2	1 1/4	24	28	46 1/2
48	54	2	7 1/2	1 1/4	24	28	52 1/2
54	60	2	7 1/2	1 1/4	24	28	58 1/2
60	66	2	7 1/2	1 1/4	24	28	64 1/2
72	80	2	8	1 1/4	24	28	78 1/2

Dimensions shown in inches.

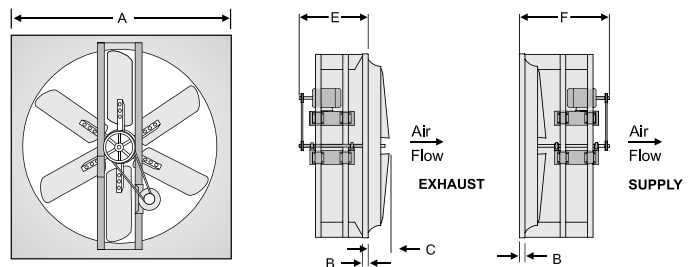

Motor Service Factor

Motor service factors are utilized in some performance selections shown. This is a safe and common industry practice that provides more performance for the investment. BHP is shown at the maximum catalog performance point. BHP at all other static pressures listed is less than that shown, in most cases substantially less. Because the motors are in the air stream there are no negative effects on motor life. Explosion proof and 2 speed motor applications are recommended at or below their nominal BHP levels. If desired, pick the next higher horsepower to eliminate this service factor usage. Refer to the Optimizer Fan Selection Program for actual BHP at any performance point.

1 year fan housing warranty, 1 year motor warranty



PERFORMANCE

Model LC Size 20

Limits			Panel OD Square	Min. Wall Opening	Damper OD	Approx. Wt
Model	RPM	Motor Frame				
LC	1350	56H	24	25 1/2	22 1/2	85

	Size	Motor HP	Max BHP	Fan RPM	Sones (0.00" SP)	Static Pressure (Inches W.G)								
						.000	.100	.125	.150	.200	.250	.300	.375	.500
Level 1 Construction	Model LC 20	1/4	0.25	905	10.5	3774	3364	3247	3113	-	-	-	-	-
			0.27	920	10.8	3837	3435	3321	3193	2829	-	-	-	-
			0.28	930	11.0	3879	3482	3370	3246	2900	-	-	-	-
			0.29	945	11.3	3941	3553	3442	3324	3002	-	-	-	-
			0.30	955	11.5	3983	3600	3491	3375	3067	-	-	-	-
		1/3	0.33	990	12.2	4129	3762	3658	3550	3283	-	-	-	-
			0.34	1000	12.5	4171	3809	3706	3599	3341	-	-	-	-
			0.36	1015	12.8	4233	3878	3776	3673	3428	-	-	-	-
			0.38	1030	13.1	4296	3947	3847	3746	3512	3173	-	-	-
			0.40	1050	13.5	4379	4038	3941	3842	3621	3312	-	-	-
		1/2	0.47	1110	14.8	4629	4311	4221	4128	3933	3689	-	-	-
			0.50	1125	15.1	4692	4378	4291	4199	4009	3776	3452	-	-
			0.55	1145	15.5	4775	4468	4383	4293	4108	3890	3593	2783	-
			0.57	1160	15.9	4838	4536	4451	4364	4182	3973	3694	2959	-
			0.60	1180	16.4	4921	4625	4543	4457	4280	4081	3822	3182	-
		3/4	0.70	1260	18.3	5255	4981	4905	4827	4664	4493	4293	3875	-
			0.75	1295	19.1	5401	5135	5062	4987	4829	4666	4484	4117	-
			0.79	1320	19.7	5505	5245	5174	5101	4947	4788	4616	4278	-
0.82	1335		20	5568	5311	5241	5169	5018	4861	4693	4371	-		
0.90	1350		20	5630	5377	5308	5237	5088	4934	4770	4462	3538		

Performance ratings do not include the effects of appurtenances (accessories).

Power ratings (BHP) do not include transmission losses.

Performance certified is for installation type A-free inlet, free outlet.

The sound ratings shown are loudness values in fan sones @ 5' (1.5m) in a hemispherical free field calculated per AMCA Standard 301. Values shown are for installation Type A-Free inlet fan sone levels.

Due to air stream cooling, the motor loading into the service factor shown does not overheat the motor and is within NEMA recommended limits. BHP at most static pressure points is less than the maximum power shown - in many cases substantially less. Use Optimizer to see the exact BHP for your selection.



S&P, Div. of Soler & Palau Ventilation Group, certifies that the models shown herein are licensed to bear the AMCA Seal. The ratings shown are based on test and procedures performed in accordance with AMCA Publication 211 and AMCA Publication 311 and comply with the requirement of the AMCA Certified Ratings Program.



Standard 705



Model LC and Model L2

Size 24



S&P, Div. of Soler & Palau Ventilation Group, certifies that the models shown herein are licensed to bear the AMCA Seal. The ratings shown are based on test and procedures performed in accordance with AMCA Publication 211 and AMCA Publication 311 and comply with the requirement of the AMCA Certified Ratings Program.



Limits			Panel OD Square	Min. Wall Opening	Damper OD	Approx. Wt.
Model	RPM	Motor Frame				
LC	1100	145T	30	31 1/2	28 1/2	90
L2	1145	145T	30	31 1/2	28 1/2	120

Size	Motor HP	Max BHP	Fan RPM	Sones (0.00" SP)	Static Pressure (Inches W.G)									
					.000	.100	.125	.150	.200	.250	.300	.375	.500	.625
Level 1 Construction Model LC 24	1/4	0.25	555	9.0	4931	4168	3905	3574	2256	-	-	-	-	-
		0.27	570	9.4	5065	4332	4085	3787	2460	-	-	-	-	-
		0.30	600	10.2	5331	4652	4431	4180	3501	2269	-	-	-	-
	1/3	0.33	625	10.9	5553	4912	4709	4482	3891	-	-	-	-	-
		0.36	645	11.6	5731	5117	4926	4715	4187	-	-	-	-	-
		0.41	660	12.1	5864	5268	5086	4885	4398	3702	-	-	-	-
	1/2	0.50	715	14.0	6353	5815	5658	5487	5097	4592	-	-	-	-
		0.54	735	14.7	6531	6011	5861	5699	5332	4877	-	-	-	-
		0.58	750	15.3	6664	6157	6012	5856	5504	5081	4535	-	-	-
	3/4	0.60	760	15.7	6753	6254	6112	5959	5617	5212	4686	-	-	-
		0.75	820	17.9	7286	6831	6704	6570	6276	5941	5577	-	-	-
		0.80	840	18.6	7464	7021	6898	6770	6489	6170	5804	-	-	-
	1	0.85	855	19.1	7597	7163	7044	6918	6646	6340	5991	5316	-	-
		0.90	875	19.8	7775	7352	7237	7116	6855	6562	6234	5600	-	-
		1.00	905	21	8041	7635	7524	7409	7163	6890	6586	6040	-	-
	1 1/2	1.10	935	22	8308	7916	7810	7700	7467	7211	6927	6437	-	-
		1.20	950	22	8441	8057	7953	7845	7618	7369	7094	6625	5559	-
		1.50	1035	25	9196	8847	8754	8658	8458	8244	8013	7628	6836	-
2	1.65	1070	27	9507	9170	9081	8989	8798	8595	8378	8019	7308	-	
	1.82	1100	28	9774	9447	9361	9272	9088	8894	8687	8347	7688	6808	
Level 2 Construction Model L2 24	1/4	0.25	540	9.9	5317	4075	3362	2733	-	-	-	-	-	
		0.27	555	10.9	5464	4290	3707	2948	-	-	-	-	-	
		0.30	575	12.2	5661	4559	4098	3307	-	-	-	-	-	
	1/3	0.33	590	13.2	5809	4753	4346	3647	-	-	-	-	-	
		0.36	605	14.3	5957	4943	4574	3995	2908	-	-	-	-	
		0.40	630	16.3	6203	5255	4926	4491	3247	-	-	-	-	
	1/2	0.50	670	17.9	6597	5740	5446	5116	3951	3168	-	-	-	
		0.57	685	18.5	6744	5917	5634	5326	4299	3364	2859	-	-	
		0.60	700	19.0	6892	6090	5822	5528	4645	3568	3043	-	-	
	3/4	0.75	740	21	7286	6543	6310	6042	5396	4220	3549	2883	-	
		0.80	765	22	7532	6816	6605	6354	5782	4786	3882	3186	-	
		0.86	795	23	7827	7138	6951	6724	6205	5455	4325	3555	-	
	1	0.90	815	24	8024	7350	7177	6964	6471	5827	4716	3807	-	
		1.00	855	26	8418	7772	7618	7432	6983	6460	5636	4337	-	
		1.05	870	27	8566	7930	7779	7604	7170	6677	5958	4551	-	
	1 1/2	1.11	890	28	8763	8139	7933	7831	7420	6953	6335	4853	-	
		1.20	910	29	8960	8347	8205	8055	7667	7220	6668	5246	-	
		1.50	975	33	9600	9021	8890	8756	8440	8045	7618	6707	4842	
2	1.66	1015	35	9994	9434	9308	9180	8899	8542	8145	7416	5409		
	1.80	1045	38	10289	9742	9620	9496	9236	8905	8526	7880	5900		
	2.00	1075	41	10584	10050	9930	9811	9566	9260	8900	8300	6600		
2.37	1145	51	11273	10766	10652	10540	10315	10065	9758	9237	8108	6204		

Performance ratings do not include the effects of appurtenances (accessories).

Power ratings (BHP) do not include transmission losses.

Performance certified is for installation type A-free inlet, free outlet.

The sound ratings shown are loudness values in fan sones @ 5' (1.5m) in a hemispherical free field calculated per AMCA Standard 301. Values shown are for installation Type A-Free inlet fan sone levels.

Due to air stream cooling, the motor loading into the service factor shown does not overheat the motor and is within NEMA recommended limits. BHP at most static pressure points is less than the maximum power shown - in many cases substantially less. Use Optimizer to see the exact BHP for your selection.



MODELS LCE/LCS, L2E/L2S, L3E/L3S
BELT DRIVE SIDEWALL PROPELLER FANS



Model LC and Model L2

Size 30



S&P, Div. of Soler & Palau Ventilation Group, certifies that the models shown herein are licensed to bear the AMCA Seal. The ratings shown are based on test and procedures performed in accordance with AMCA Publication 211 and AMCA Publication 311 and comply with the requirement of the AMCA Certified Ratings Program.

Model	Limits		Panel OD Square	Min. Wall Opening	Damper OD	Approx. Wt
	RPM	Motor Frame				
LC	815	145T	36	37 1/2	34 1/2	100
L2	1070	182T	36	37 1/2	34 1/2	180



Size	Motor HP	Max BHP	Fan RPM	Sones (0.00" SP)	Static Pressure (Inches W.G)									
					.000	.100	.125	.150	.200	.250	.300	.375	.500	
Level 1 Construction	Model LC 30	1/4	0.25	425	8.3	6956	5509	4962	4215	-	-	-	-	-
			0.27	435	8.6	7119	5735	5212	4608	-	-	-	-	-
			0.30	450	9.0	7365	6062	5572	5034	-	-	-	-	-
		1/3	0.33	465	9.5	7610	6370	5922	5422	-	-	-	-	-
			0.36	480	9.9	7856	6665	6270	5794	-	-	-	-	-
			0.40	495	10.5	8101	6954	6603	6152	5073	-	-	-	-
	1/2	0.50	535	12.0	8756	7709	7419	7074	6211	-	-	-	-	
		0.55	550	12.7	9001	7988	7709	7400	6586	5511	-	-	-	
		0.59	565	13.3	9247	8271	7995	7712	6949	6052	-	-	-	
	3/4	0.75	610	15.3	9983	9117	8839	8589	7995	7242	6351	-	-	
		0.82	630	16.2	10311	9487	9216	8968	8436	7728	6945	-	-	
		0.90	650	17.1	10638	9853	9594	9343	8857	8198	7473	-	-	
	1	1.00	670	18.0	10965	10216	9969	9716	9253	8665	7978	6549	-	
		1.11	695	19.3	11375	10665	10434	10188	9738	9228	8581	7501	-	
		1.20	715	20	11702	11021	10802	10565	10120	9659	9098	8052	-	
	1 1/2	1.50	770	23	12602	11990	11798	11589	11151	10752	10298	9427	-	
		1.63	790	23	12929	12339	12156	11956	11526	11135	10723	9899	8281	
		1.78	815	24	13339	12773	12599	12411	12000	11609	11223	10482	9013	
Level 2 Construction	Model L2 30	1/3	0.33	480	9.7	7675	6417	5879	5284	-	-	-	-	
			0.36	495	10.3	7915	6706	6243	5678	-	-	-	-	
			0.40	505	10.7	8075	6895	6481	5932	4378	-	-	-	
		1/2	0.50	550	12.6	8794	7720	7432	7025	5986	-	-	-	
			0.56	570	13.6	9114	8078	7809	7479	6516	-	-	-	
			0.60	585	14.4	9354	8345	8087	7799	6896	-	-	-	
	3/4	0.75	630	17.6	10073	9146	8902	8659	7991	7096	-	-		
		0.83	650	18.4	10393	9499	9258	9026	8455	7609	6642	-		
		0.90	670	19.2	10713	9850	9614	9390	8890	8101	7200	-		
	1	1.00	685	19.9	10953	10112	9882	9659	9194	8460	7638	5700	-	
		1.10	710	21	11352	10546	10325	10106	9672	9068	8284	6802	-	
		1.20	735	22	11752	10978	10766	10550	10137	9637	8900	7679	-	
	1 1/2	1.50	795	25	12711	12004	11812	11615	11226	10836	10331	9292	-	
		1.65	820	26	13111	12428	12243	12054	11672	11302	10876	9908	-	
		1.80	845	27	13511	12851	12673	12490	12116	11760	11378	10510	-	
	2	2.00	875	29	13991	13356	13185	13010	12651	12303	11948	11233	9600	
		2.22	905	31	14470	13859	13696	13528	13183	12840	12504	11907	10399	
		2.40	930	32	14870	14278	14119	13957	13623	13284	12961	12435	11029	
3	3.00	1005	37	16069	15525	15381	15234	14930	14618	14308	13855	12846		
	3.30	1040	41	16629	16105	15967	15825	15534	15235	14930	14495	13600		
	3.60	1070	44	17109	16601	16467	16330	16049	15761	15465	15038	14279		

Performance ratings do not include the effects of appurtenances (accessories).

Power ratings (BHP) do not include transmission losses.

Performance certified is for installation type A-free inlet, free outlet.

The sound ratings shown are loudness values in fan sones @ 5' (1.5m) in a hemispherical free field calculated per AMCA Standard 301. Values shown are for installation Type A-Free inlet fan sone levels.

Due to air stream cooling, the motor loading into the service factor shown does not overheat the motor and is within NEMA recommended limits. BHP at most static pressure points is less than the maximum power shown - in many cases substantially less. Use Optimizer to see the exact BHP for your selection.



Model LC and Model L2

Size 36

Limits			Panel OD Square	Min. Wall Opening	Damper OD	Approx. Wt
Model	RPM	Motor Frame				
LC	695	145T	42	43 1/2	40 1/2	105
L2	845	184T	42	43 1/2	40 1/2	215



S&P, Div. of Soler & Palau Ventilation Group, certifies that the models shown herein are licensed to bear the AMCA Seal. The ratings shown are based on test and procedures performed in accordance with AMCA Publication 211 and AMCA Publication 311 and comply with the requirement of the AMCA Certified Ratings Program.



Size	Motor HP	Max BHP	Fan RPM	Sones (0.00" SP)	Static Pressure (Inches W.G)											
					.000	.100	.125	.150	.200	.250	.300	.375	.500	.625	.750	
Level 1 Construction Model LC 36	1/3	0.33	360	8.5	9927	7580	6735	5537	-	-	-	-	-	-	-	-
		0.35	370	8.9	10203	7973	7153	6222	-	-	-	-	-	-	-	-
		0.41	390	9.7	10755	8745	7976	7190	-	-	-	-	-	-	-	-
	1/2	0.50	415	10.8	11444	9631	8967	8237	6333	-	-	-	-	-	-	-
		0.55	430	11.5	11858	10126	9550	8849	7340	-	-	-	-	-	-	-
		0.59	440	11.9	12133	10449	9923	9248	7840	-	-	-	-	-	-	-
	3/4	0.75	475	13.7	13098	11556	11133	10611	9337	7872	-	-	-	-	-	-
		0.82	490	14.5	13512	12022	11620	11162	9954	8675	-	-	-	-	-	-
		0.90	505	15.3	13926	12485	12100	11686	10557	9348	7384	-	-	-	-	-
	1	1.00	525	16.4	14477	13103	12731	12348	11345	10187	8897	-	-	-	-	-
		1.09	540	17.3	14891	13562	13199	12834	11930	10809	9653	-	-	-	-	-
		1.19	555	18.1	15305	14018	13663	13312	12495	11419	10317	-	-	-	-	-
	1 1/2	1.50	600	20	16545	15373	15048	14720	14055	13195	12186	10619	-	-	-	-
		1.58	610	21	16821	15671	15353	15029	14381	13577	12590	11076	-	-	-	-
		1.79	635	22	17511	16413	16111	15801	15186	14497	13578	12146	-	-	-	-
	2	2.00	655	23	18062	17003	16713	16415	15819	15189	14366	12975	9909	-	-	-
		2.22	680	24	18751	17737	17461	17177	16600	16014	15313	13996	11612	-	-	-
		2.37	695	25	19165	18176	17907	17631	17065	16499	15859	14594	12363	-	-	-
Level 2 Construction Model L2 36	1/2	0.49	410	11.5	10401	9012	8530	7939	6101	3751	2429	-	-	-	-	
		0.52	420	11.9	10655	9315	8862	8318	6704	4304	2801	-	-	-	-	
		0.56	430	12.4	10908	9615	9187	8682	7248	4924	3207	-	-	-	-	
	3/4	0.74	470	14.5	11923	10781	10428	10030	9033	7519	5326	3148	-	-	-	
		0.83	490	15.6	12430	11349	11024	10663	9790	8565	6673	3997	-	-	-	
		0.88	500	16.1	12684	11631	11317	10971	10148	9030	7335	4483	-	-	-	
	1	1.02	520	17.3	13191	12189	11896	11578	10836	9880	8524	5609	2815	-	-	
		1.12	540	18.5	13699	12742	12467	12171	11495	10656	9537	6926	3530	-	-	
		1.17	550	19.1	13952	13017	12750	12464	11815	11024	9994	7606	3926	-	-	
	1.5	1.48	590	22	14967	14106	13867	13613	13054	12403	11615	9987	5858	3443	-	
		1.60	610	23	15474	14646	14418	14178	13654	13053	12345	10952	7086	4191	-	
		1.83	630	24	15982	15183	14966	14738	14243	13685	13040	11820	8438	5041	3220	
	2	1.97	650	25	16489	15718	15510	15292	14824	14302	13708	12619	9756	6021	3903	
		2.12	670	27	16997	16251	16051	15843	15399	14907	14356	13370	10932	7161	4662	
		2.30	690	28	17504	16782	16590	16391	15967	15502	14987	14084	11969	8455	5516	
	3	2.84	740	31	18772	18102	17927	17746	17366	16956	16511	15758	14158	11709	8221	
		3.14	765	33	19407	18759	18592	18419	18057	17669	17251	16554	15119	13062	9885	
		3.53	795	35	20168	19546	19386	19222	18879	18514	18125	17483	16202	14476	11880	
5	4.86	890	43	22578	22023	21883	21741	21447	21139	20816	20298	19323	18155	16676		
	5.33	920	46	23339	22801	22667	22531	22249	21955	21648	21158	20249	19182	17876		
	5.66	940	48	23846	23320	23189	23056	22782	22497	22199	21727	20856	19845	18631		

Performance ratings do not include the effects of appurtenances (accessories).

Power ratings (BHP) do not include transmission losses.

Performance certified for installation type A-free inlet, free outlet.

The sound ratings shown are loudness values in fan sones @ 5' (1.5m) in a hemispherical free field calculated per AMCA Standard 301. Values shown are for installation Type A-Free inlet fan sone levels.

Due to air stream cooling, the motor loading into the service factor shown does not overheat the motor and is within NEMA recommended limits. BHP at most static pressure points is less than the maximum power shown - in many cases substantially less. Use Optimizer to see the exact BHP for your selection.



MODELS LCE/LCS, L2E/L2S, L3E/L3S
BELT DRIVE SIDEWALL PROPELLER FANS



Model LC, Model L2 and Model L3

Size 42

Model	Limits		Panel OD Square	Min. Wall Opening	Damper OD	Approx. Wt
	RPM	Motor Frame				
LC	550	145T	48	49 1/2	46 1/2	110
L2	745	184T	48	49 1/2	46 1/2	235
L3	850	213T	48	49 1/2	46 1/2	260



S&P, Div. of Soler & Palau Ventilation Group, certifies that the models shown herein are licensed to bear the AMCA Seal. The ratings shown are based on test and procedures performed in accordance with AMCA Publication 211 and AMCA Publication 311 and comply with the requirement of the AMCA Certified Ratings Program.

LC:



Standard 705

L2 & L3:



Standard 705

Construction	Model	Size	Motor HP	Max BHP	Fan RPM	Sones (0.10" SP)	Static Pressure (Inches W.G)												
							.000	.100	.125	.150	.200	.250	.300	.375	.500	.625	.750		
Level 1 Construction	Model LC 42	1/3	0.33	285	8.3	12309	8342	6281	-	-	-	-	-	-	-	-	-	-	
			0.37	295	8.3	12741	8967	7579	-	-	-	-	-	-	-	-	-	-	-
			0.41	305	8.4	13173	9658	8439	5438	-	-	-	-	-	-	-	-	-	-
		1/2	0.50	325	8.8	14037	10969	9725	8483	-	-	-	-	-	-	-	-	-	-
			0.54	335	9.3	14469	11549	10380	9305	-	-	-	-	-	-	-	-	-	-
			0.60	345	9.8	14901	12109	11073	9960	-	-	-	-	-	-	-	-	-	-
		3/4	0.75	375	11.4	16197	13705	12938	11928	9768	-	-	-	-	-	-	-	-	-
			0.83	385	12.0	16629	14218	13498	12606	10619	-	-	-	-	-	-	-	-	-
			0.90	395	12.6	17060	14724	14044	13252	11285	7292	-	-	-	-	-	-	-	-
	1	1.00	410	13.4	17708	15474	14842	14128	12233	9895	-	-	-	-	-	-	-	-	
		1.11	425	14.3	18356	16214	15618	14966	13217	11433	6467	-	-	-	-	-	-	-	
		1.20	435	14.9	18788	16703	16128	15508	13911	12182	8485	-	-	-	-	-	-	-	
	1 1/2	1.50	470	16.9	20300	18400	17874	17336	16118	14419	12885	-	-	-	-	-	-	-	
		1.65	485	17.9	20948	19119	18609	18095	16964	15460	13900	9198	-	-	-	-	-	-	
		1.81	500	18.8	21596	19833	19339	18845	17784	16470	14848	11827	-	-	-	-	-	-	
	2	2.00	515	19.8	22243	20543	20067	19587	18583	17410	15805	13517	-	-	-	-	-	-	
		2.22	535	21	23107	21482	21029	20566	19623	18561	17190	15068	-	-	-	-	-	-	
		2.40	550	22	23755	22182	21746	21295	20388	19393	18190	16034	-	-	-	-	-	-	
Level 2 Construction	Model L2 42	1/3	0.33	285	7.8	10509	7477	5671	3612	-	-	-	-	-	-	-	-	-	
			0.36	290	8.0	10694	7789	6342	4014	-	-	-	-	-	-	-	-	-	
			0.40	300	8.1	11062	8381	7206	4906	-	-	-	-	-	-	-	-	-	
		1/2	0.50	325	8.9	11984	9671	8755	7643	-	-	-	-	-	-	-	-	-	-
			0.55	335	9.4	12353	10149	9347	8304	-	-	-	-	-	-	-	-	-	-
			0.60	345	10.0	12722	10621	9901	8910	-	-	-	-	-	-	-	-	-	-
		3/4	0.75	370	11.5	13644	11823	11131	10411	8367	-	-	-	-	-	-	-	-	-
			0.84	385	12.4	14197	12521	11841	11206	9474	6112	-	-	-	-	-	-	-	-
			0.90	395	13.0	14566	12972	12316	11697	10087	7124	-	-	-	-	-	-	-	-
	1	1.00	405	13.7	14934	13406	12803	12178	10697	8279	-	-	-	-	-	-	-	-	
		1.10	420	14.6	15487	14041	13516	12889	11606	9898	6533	-	-	-	-	-	-	-	
		1.20	435	15.7	16041	14664	14206	13604	12449	10877	8053	-	-	-	-	-	-	-	
	1 1/2	1.50	470	18.0	17331	16089	15716	15265	14174	13001	11506	7343	-	-	-	-	-	-	
		1.66	485	19.0	17884	16689	16339	15942	14884	13846	12428	8858	-	-	-	-	-	-	
		1.81	495	19.6	18253	17088	16750	16375	15354	14366	13037	9983	-	-	-	-	-	-	
	2	2.00	515	21	18990	17880	17564	17222	16325	15345	14250	12166	-	-	-	-	-	-	
		2.24	535	22	19728	18666	18369	18052	17271	16299	15368	13458	-	-	-	-	-	-	
		2.42	550	23	20281	19253	18969	18666	17959	17006	16121	14360	9183	-	-	-	-	-	
3	3.00	590	26	21756	20806	20549	20280	19690	18928	18041	16738	13692	8037	-	-	-	-		
	3.33	610	27	22494	21578	21333	21077	20524	19855	18985	17781	15060	9786	6188	-	-	-		
	3.60	625	28	23047	22156	21918	21671	21141	20531	19717	18517	15977	11312	7195	-	-	-		
	5.00	700	34	25812	25024	24818	24606	24164	23687	23156	22103	20314	17936	14112	-	-	-		
	5.52	720	36	26550	25785	25586	25382	24957	24503	24005	23060	21299	19163	16540	-	-	-		
	6.07	745	38	27472	26734	26542	26347	25942	25513	25049	24222	22500	20666	18311	-	-	-		
Level 3	Model L3 42	7 1/2	7.50	800	43	29500	28816	28639	28460	28091	27705	27298	26628	25120	23570	21683	-	-	
			8.17	825	46	30422	29759	29589	29416	29061	28692	28305	27676	26325	24778	23147	-	-	
			8.93	850	48	31344	30701	30537	30369	30027	29673	29304	28710	27497	25965	24512	-	-	

Performance ratings do not include the effects of appurtenances (accessories).

Power ratings (BHP) do not include transmission losses.

Performance certified is for installation type A-free inlet, free outlet.

The sound ratings shown are loudness values in fan sones @ 5' (1.5m) in a hemispherical free field calculated per AMCA Standard 301. Values shown are for installation Type A-Free inlet fan sone levels.

Due to air stream cooling, the motor loading into the service factor shown does not overheat the motor and is within NEMA recommended limits. BHP at most static pressure points is less than the maximum power shown - in many cases substantially less. Use Optimizer to see the exact BHP for your selection.



MODELS LCE/LCS, L2E/L2S, L3E/L3S
BELT DRIVE SIDEWALL PROPELLER FANS



Model LC, Model L2 and Model L3

Size 48



S&P, Div. of Soler & Palau Ventilation Group, certifies that the models shown herein are licensed to bear the AMCA Seal. The ratings shown are based on test and procedures performed in accordance with AMCA Publication 211 and AMCA Publication 311 and comply with the requirement of the AMCA Certified Ratings Program.

Model	Limits		Panel OD Square	Min. Wall Opening	Damper OD	Approx. Wt
	RPM	Motor Frame				
LC	455	145T	54	55 1/2	52 1/2	125
L2	605	184T	54	55 1/2	52 1/2	300
L3	765	215T	54	55 1/2	52 1/2	330



Size	Motor HP	Max BHP	Fan RPM	Sones (0.10" SP)	Static Pressure (Inches W.G)												
					.000	.100	.125	.150	.200	.250	.300	.375	.500	.625	.750		
Level 1 Construction Model LC 48	1/2	0.50	270	9.5	16739	11961	9933	-	-	-	-	-	-	-	-	-	-
		0.56	280	9.7	17359	12936	11133	6659	-	-	-	-	-	-	-	-	-
		0.62	290	10.0	17979	13841	12199	10077	-	-	-	-	-	-	-	-	-
	3/4	0.69	300	10.4	18599	14684	13193	11413	-	-	-	-	-	-	-	-	-
		0.75	310	10.9	19219	15459	14171	12556	-	-	-	-	-	-	-	-	-
		0.83	320	11.6	19839	16210	15101	13600	-	-	-	-	-	-	-	-	-
	1	0.91	330	12.1	20459	16949	15969	14584	10759	-	-	-	-	-	-	-	-
		1.00	340	12.7	21079	17678	16778	15563	12363	-	-	-	-	-	-	-	-
		1.09	350	13.4	21699	18411	17542	16493	13606	-	-	-	-	-	-	-	-
	1 1/2	1.14	355	13.7	22009	18777	17917	16936	14174	-	-	-	-	-	-	-	-
		1.23	365	14.3	22629	19504	18659	17784	15243	10868	-	-	-	-	-	-	-
		1.50	390	15.9	24179	21296	20488	19711	17720	15058	-	-	-	-	-	-	-
	2	1.63	400	16.7	24799	22004	21219	20452	18668	16187	11973	-	-	-	-	-	-
		1.82	415	17.8	25729	23054	22306	21548	19994	17746	14950	-	-	-	-	-	-
		2.00	430	18.9	26659	24093	23381	22647	21217	19215	16819	-	-	-	-	-	-
	Level 2 Construction Model L2 48	1/2	2.16	440	19.6	27279	24779	24091	23377	21983	20194	17929	-	-	-	-	-
			2.39	455	21	28209	25800	25148	24463	23107	21574	19479	15382	-	-	-	-
			0.51	265	8.9	14897	11015	9603	7178	-	-	-	-	-	-	-	-
3/4		0.55	270	9.1	15178	11448	10050	8090	-	-	-	-	-	-	-	-	
		0.60	280	9.3	15740	12285	10907	9442	-	-	-	-	-	-	-	-	
		0.69	295	10.1	16584	13462	12204	10941	-	-	-	-	-	-	-		
1		0.75	300	10.4	16865	13840	12639	11376	7002	-	-	-	-	-	-		
		0.82	310	11.2	17427	14578	13485	12223	9041	-	-	-	-	-	-		
		0.90	320	11.9	17989	15300	14290	13092	10504	-	-	-	-	-	-		
1 1/2		0.93	325	12.2	18270	15656	14681	13530	11096	-	-	-	-	-	-		
		1.00	335	13.0	18832	16352	15443	14388	12128	7739	-	-	-	-	-		
		1.13	345	13.8	19394	17033	16183	15213	13014	9825	-	-	-	-	-		
2		1.23	355	14.6	19957	17701	16908	16003	13866	11386	-	-	-	-	-		
		1.50	380	16.4	21362	19320	18656	17879	16032	14051	11129	-	-	-	-		
		1.68	395	17.5	22205	20262	19664	18958	17294	15342	13239	-	-	-	-		
3		1.80	405	18.2	22767	20884	20322	19661	18094	16184	14339	-	-	-	-		
		2.00	420	19.4	23611	21808	21293	20689	19252	17504	15719	-	-	-	-		
		2.20	430	20	24173	22419	21926	21361	20000	18365	16577	13276	-	-	-		
5	2.40	445	21	25016	23331	22864	22350	21095	19608	17847	15192	-	-	-			
	3.00	480	24	26983	25436	25020	24580	23553	22305	20871	18470	12309	-	-			
	3.36	495	25	27827	26331	25932	25514	24564	23402	22080	19734	15092	-	-			
7 1/2	3.62	510	27	28670	27222	26838	26439	25556	24479	23245	21054	17098	-	-			
	5.00	565	31	31762	30464	30127	29781	29053	28231	27262	25589	22235	18481	-			
	5.44	585	33	32886	31635	31311	30980	30290	29535	28650	27105	23969	20741	-			
Level 3 Construction Model L3 48	6.13	605	35	34010	32802	32491	32174	31516	30811	30001	28571	25707	22582	14450			
	7.50	650	40	36540	35419	35132	34841	34243	33616	32945	31753	29362	26441	23603			
	8.11	670	42	37664	36578	36300	36020	35444	34844	34209	33113	30886	28190	25367			
	9.05	695	45	39070	38023	37757	37487	36937	36367	35770	34774	32730	30306	27485			
	10.00	720	48	40475	39466	39210	38951	38423	37880	37314	36401	34530	32304	29666			
	10.88	740	50	41600	40618	40369	40118	39607	39083	38540	37674	35937	33846	31401			
	12.00	765	52	43005	42056	41816	41574	41083	40580	40061	39243	37651	35714	33496			

Performance ratings do not include the effects of appurtenances (accessories).

Power ratings (BHP) do not include transmission losses.

Performance certified is for installation type A-free inlet, free outlet.

The sound ratings shown are loudness values in fan sones @ 5' (1.5m) in a hemispherical free field calculated per AMCA Standard 301. Values shown are for installation Type A-Free inlet fan sone levels.

Due to air stream cooling, the motor loading into the service factor shown does not overheat the motor and is within NEMA recommended limits. BHP at most static pressure points is less than the maximum power shown - in many cases substantially less. Use Optimizer to see the exact BHP for your selection.



MODELS LCE/LCS, L2E/L2S, L3E/L3S
BELT DRIVE SIDEWALL PROPELLER FANS



Model LC, Model L2 and Model L3

Size 54



S&P, Div. of Soler & Palau Ventilation Group, certifies that the models shown herein are licensed to bear the AMCA Seal. The ratings shown are based on test and procedures performed in accordance with AMCA Publication 211 and AMCA Publication 311 and comply with the requirement of the AMCA Certified Ratings Program.

Model	Limits		Panel OD Square	Min. Wall Opening	Damper OD	Approx. Wt
	RPM	Motor Frame				
LC	425	182T	60	61 1/2	58 1/2	240
L2	515	184T	60	61 1/2	58 1/2	400
L3	740	256T	60	61 1/2	58 1/2	500



Construction	Model	Size	Motor HP	Max BHP	Fan RPM	Sones (0.15" SP)	Static Pressure (Inches W.G)													
							.000	.125	.150	.200	.250	.300	.375	.500	.625	.750				
Level 1 Construction	Model LC 54	3/4	0.75	250	9.8	21652	14977	10311	-	-	-	-	-	-	-	-	-			
			0.82	260	10.4	22518	16507	13479	-	-	-	-	-	-	-	-	-	-		
			0.92	270	11.0	23384	17932	15352	10232	-	-	-	-	-	-	-	-	-		
		1	1.00	275	11.4	23817	18559	16095	11620	-	-	-	-	-	-	-	-	-		
			1.09	285	12.3	24683	19720	17561	14816	-	-	-	-	-	-	-	-	-		
			1.20	295	13.1	25550	20825	19097	16699	-	-	-	-	-	-	-	-	-		
		1 1/2	1.50	315	14.8	27282	22932	21633	19683	12699	-	-	-	-	-	-	-	-		
			1.61	325	15.5	28148	23950	22757	21183	15785	-	-	-	-	-	-	-	-		
			1.84	340	16.8	29447	25449	24372	23109	19183	-	-	-	-	-	-	-	-		
		2	2.00	350	17.7	30313	26434	25414	24259	20671	13599	-	-	-	-	-	-	-		
			2.19	360	18.5	31179	27408	26437	25365	22133	16456	-	-	-	-	-	-	-		
			2.38	370	19.4	32045	28375	27445	26439	23692	19651	-	-	-	-	-	-	-		
		3	3.00	400	22	34643	31236	30401	29530	27543	24351	20039	-	-	-	-	-	-		
			3.35	415	23	35943	32648	31852	31029	29213	26686	23274	-	-	-	-	-	-		
			3.60	425	24	36809	33585	32812	32015	30290	28100	24785	15677	-	-	-	-	-		
		Level 2 Construction	Model L2 54	1	1.00	280	12.9	22680	17068	15430	10747	-	-	-	-	-	-	-	-	
					1.08	290	12.8	23490	18289	16585	13352	-	-	-	-	-	-	-	-	-
					1.20	300	13.3	24300	19435	17847	14940	-	-	-	-	-	-	-	-	-
1 1/2	1.50			325	14.7	26325	22071	20881	18012	15063	-	-	-	-	-	-	-	-		
	1.66			335	15.3	27135	23051	21991	19167	16645	-	-	-	-	-	-	-	-		
	1.82			345	15.9	27945	24009	23055	20429	17977	13943	-	-	-	-	-	-	-		
2	2.00			355	16.5	28755	24951	24076	21693	19167	16320	-	-	-	-	-	-	-		
	2.14			370	17.4	29970	26337	25543	23506	20904	18665	-	-	-	-	-	-	-		
	2.42			380	18.1	30780	27250	26496	24642	22110	19943	12875	-	-	-	-	-	-		
3	3.00			405	19.8	32805	29495	28822	27307	25251	22863	19592	-	-	-	-	-	-		
	3.26			420	21	34020	30816	30188	28793	27006	24696	21705	-	-	-	-	-	-		
	3.63			435	22	35235	32123	31538	30237	28662	26595	23500	-	-	-	-	-	-		
5	5.00			485	27	39285	36430	35924	34861	33677	32300	29567	25066	-	-	-	-	-		
	5.35			495	28	40095	37284	36789	35763	34624	33339	30803	26276	19008	-	-	-	-		
	6.04			515	29	41715	38988	38510	37550	36487	35323	33144	28610	24012	-	-	-	-		
Level 3 Construction	Model L3 54	7 1/2	6.94	540	31	43740	41110	40651	39742	38772	37717	35876	31600	27746	19763	-				
			7.50	555	33	44955	42378	41930	41046	40126	39121	37436	33508	29564	24604	-				
			8.60	580	35	46980	44488	44055	43206	42356	41424	39902	36579	32473	28797	-				
		10	10.00	610	38	49410	47011	46594	45782	44978	44138	42758	39973	36128	32626	-				
			11.06	630	40	51030	48690	48283	47491	46713	45923	44619	42105	38653	34954	-				
			12.15	650	42	52650	50364	49967	49195	48439	47682	46454	44142	41077	37264	-				
		15	15.00	700	48	56700	54541	54164	53434	52725	52024	50955	48962	46617	43558	-				
			16.45	720	51	58320	56207	55837	55123	54430	53747	52721	50830	48684	45923	-				
			17.85	740	53	59940	57872	57509	56809	56130	55464	54469	52675	50659	48179	-				

Performance ratings do not include the effects of appurtenances (accessories).

Power ratings (BHP) do not include transmission losses.

Performance certified is for installation type A-free inlet, free outlet.

The sound ratings shown are loudness values in fan sones @ 5' (1.5m) in a hemispherical free field calculated per AMCA Standard 301. Values shown are for installation Type A-Free inlet fan sone levels.

Due to air stream cooling, the motor loading into the service factor shown does not overheat the motor and is within NEMA recommended limits. BHP at most static pressure points is less than the maximum power shown - in many cases substantially less. Use Optimizer to see the exact BHP for your selection.



MODELS LCE/LCS, L2E/L2S, L3E/L3S
BELT DRIVE SIDEWALL PROPELLER FANS



Model LC, Model L2 and Model L3

Size 60



S&P, Div. of Soler & Palau Ventilation Group, certifies that the models shown herein are licensed to bear the AMCA Seal. The ratings shown are based on test and procedures performed in accordance with AMCA Publication 211 and AMCA Publication 311 and comply with the requirement of the AMCA Certified Ratings Program.

Model	Limits		Panel OD Square	Min. Wall Opening	Damper OD	Approx. Wt
	RPM	Motor Frame				
LC	380	182T	66	67 1/2	64 1/2	285
L2	460	184T	66	67 1/2	64 1/2	490
L3	700	256T	66	67 1/2	64 1/2	530



Construction	Size	Motor HP	Max BHP	Fan RPM	Sones (0.00" SP)	Static Pressure (Inches W.G)									
						.000	.125	.150	.200	.250	.375	.500	.625	.750	1.000
Level 1 Construction	Model LC 60	1	1.00	250	10.3	26878	20089	16672	-	-	-	-	-	-	-
			1.08	255	10.7	27416	20835	18009	-	-	-	-	-	-	-
			1.21	265	11.5	28491	22275	20109	-	-	-	-	-	-	-
		1 1/2	1.50	285	13.0	30641	25041	23280	20999	-	-	-	-	-	-
			1.69	295	13.9	31717	26369	24721	22844	-	-	-	-	-	-
			1.75	300	14.3	32254	27023	25433	23649	-	-	-	-	-	-
		2	2.00	310	15.1	33329	28317	26824	25176	18811	-	-	-	-	-
			2.23	325	16.3	34942	30222	28846	27344	23361	-	-	-	-	-
			2.44	335	17.1	36017	31464	30159	28751	25399	-	-	-	-	-
	3	3.03	360	19.1	38705	34490	33367	32125	29373	25314	-	-	-	-	
		3.29	370	20	39780	35672	34618	33430	30822	27531	-	-	-	-	
		3.56	380	21	40855	36826	35849	34723	32244	29351	-	-	-	-	
	Level 2 Construction	Model L2 60	1	1.00	250	9.9	25631	17744	15842	-	-	-	-	-	-
				1.08	260	10.6	26656	19351	17368	-	-	-	-	-	-
				1.21	270	11.3	27681	20986	18860	15136	-	-	-	-	-
1 1/2			1.50	290	12.7	29732	23756	22062	18500	-	-	-	-	-	
			1.67	300	13.4	30757	25033	23639	20021	16501	-	-	-	-	
			1.83	310	14.2	31782	26280	25017	21513	18376	-	-	-	-	
2			2.00	320	15.0	32808	27513	26324	23013	20017	-	-	-	-	
			2.11	325	15.4	33320	28131	26963	23823	20803	-	-	-	-	
			2.22	330	15.8	33833	28744	27594	24667	21569	-	-	-	-	
3		3.00	365	19.0	37421	32929	31915	29813	26912	19530	-	-	-		
		3.38	380	20	38959	34674	33724	31731	29390	22561	-	-	-		
		3.64	390	21	39984	35821	34914	32979	30912	24209	-	-	-		
5		5.00	435	25	44598	40862	40121	38488	36744	31031	25399	-	-		
		5.60	450	26	46136	42519	41809	40275	38594	33461	27901	-	-		
		5.98	460	27	47161	43618	42926	41454	39830	35125	29479	-	-		
Level 3 Construction	Model L3 60	7 1/2	7.03	485	29	49724	46353	45700	44359	42869	38864	33248	28162	-	
			7.50	495	30	50749	47441	46803	45502	44065	40196	34740	29870	-	
			7.91	505	31	51774	48527	47902	46633	45252	41497	36241	31497	-	
			9.09	530	34	54338	51231	50636	49437	48180	44658	40368	35343	30623	
		10	10.00	545	35	55875	52847	52268	51107	49912	46512	42747	37583	33176	-
			10.78	560	37	57413	54459	53895	52767	51617	48365	44872	39824	35577	-
			11.98	580	39	59464	56603	56058	54969	53868	50812	47513	43039	38629	-
		15	15.00	625	44	64077	61406	60896	59886	58874	56189	53177	50021	45397	37596
			16.48	645	47	66128	63532	63037	62056	61078	58529	55646	52673	48763	40825
			17.98	665	49	68178	65654	65173	64219	63271	60843	58098	55240	51973	43894

Performance ratings do not include the effects of appurtenances (accessories).

Power ratings (BHP) do not include transmission losses.

Performance certified for installation type A-free inlet, free outlet.

The sound ratings shown are loudness values in fan sones @ 5' (1.5m) in a hemispherical free field calculated per AMCA Standard 301. Values shown are for installation Type A-Free inlet fan sone levels.

Due to air stream cooling, the motor loading into the service factor shown does not overheat the motor and is within NEMA recommended limits. BHP at most static pressure points is less than the maximum power shown - in many cases substantially less. Use Optimizer to see the exact BHP for your selection.



MODELS LCE/LCS, L2E/L2S, L3E/L3S
BELT DRIVE SIDEWALL PROPELLER FANS



Model L3
Size 72



S&P, Div. of Soler & Palau Ventilation Group, certifies that the models shown herein are licensed to bear the AMCA Seal. The ratings shown are based on test and procedures performed in accordance with AMCA Publication 211 and AMCA Publication 311 and comply with the requirement of the AMCA Certified Ratings Program.



Limits			Panel OD Square	Min. Wall Opening	Damper OD	Approx. Wt
Model	RPM	Motor Frame				
L3	545	256T	80	81 1/2	78 1/2	600

Size	Motor HP	Max BHP	Fan RPM	Sones (0.00" SP)	Static Pressure (Inches W.G)												
					.000	.125	.200	.250	.300	.375	.500	.625	.750	1.000			
Level 3 Construction Model L3 72	1 1/2	1.29	225	22	35129	20805	-	-	-	-	-	-	-	-	-	-	-
		1.50	235	23	36690	23490	11736	-	-	-	-	-	-	-	-	-	-
		1.77	250	25	39032	28557	16766	-	-	-	-	-	-	-	-	-	-
	2	2.00	260	27	40593	30797	19872	12185	-	-	-	-	-	-	-	-	-
		2.23	270	28	42154	33105	22720	15591	-	-	-	-	-	-	-	-	-
		2.36	275	29	42935	34370	23988	17268	-	-	-	-	-	-	-	-	-
	3	3.00	295	34	46058	38778	28928	23480	16818	-	-	-	-	-	-	-	-
		3.22	305	36	47619	40624	32722	26224	20149	-	-	-	-	-	-	-	-
		3.54	315	39	49180	42421	35839	28644	23303	-	-	-	-	-	-	-	-
	5	4.26	335	44	52303	45927	40304	34243	28943	20547	-	-	-	-	-	-	-
		5.00	350	48	54645	48505	44011	39490	32581	25385	-	-	-	-	-	-	-
		5.98	375	56	58548	52752	49397	45162	40602	32470	19719	-	-	-	-	-	-
	7	6.44	385	60	60109	54439	52140	47621	43710	34888	23115	-	-	-	-	-	-
		7.50	405	64	63232	57793	54820	52395	48197	39949	29577	17215	-	-	-	-	-
		8.71	425	67	66354	61123	58310	56291	52989	47294	35402	24005	-	-	-	-	-
	10	10.00	445	69	69477	64435	61744	59908	57687	52162	40392	30620	19305	-	-	-	-
		11.04	460	71	71819	66908	64294	62555	60633	55471	44092	35242	24397	-	-	-	-
		12.15	475	74	74160	69373	66838	65165	63387	59202	48920	39535	29471	-	-	-	-
15	15.00	510	79	79625	75100	72720	71154	69590	66984	59376	48219	40396	-	-	-	-	
	16.41	525	81	81967	77547	75223	73700	72190	69767	62695	52353	44585	26079	-	-	-	
	18.36	545	85	85089	80799	78545	77078	75619	73370	67480	59891	49467	32867	-	-	-	

Performance ratings do not include the effects of appurtenances (accessories).

Power ratings (BHP) do not include transmission losses.

Performance certified is for installation type A-free inlet, free outlet.

The sound ratings shown are loudness values in fan sones @ 5' (1.5m) in a hemispherical free field calculated per AMCA Standard 301. Values shown are for installation Type A-Free inlet fan sone levels.

Due to air stream cooling, the motor loading into the service factor shown does not overheat the motor and is within NEMA recommended limits. BHP at most static pressure points is less than the maximum power shown - in many cases substantially less. Use Optimizer to see the exact BHP for your selection.